

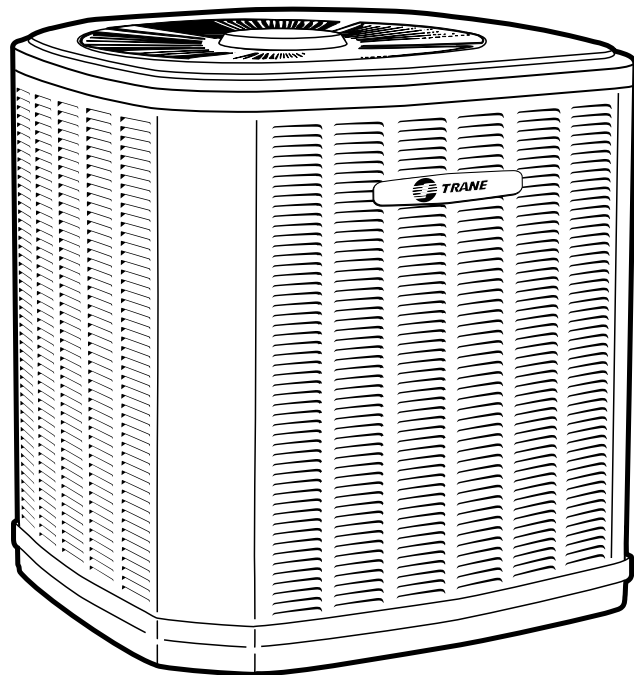

Split System Cooling Product Data

XR 13
4TTR3018-060

1½ – 5 Tons





Features and Benefits

- **Climatuff**® compressor
- Efficiency up to 14.00 SEER
- All aluminum **Spine Fin**™ coil
- **WeatherGuard**™ fasteners
- **Quick-Sess**™ cabinet, easy service access and refrigerant connections with full coil protection
- **DuraTuff**™ base, fast complete drain, weather proof
- **Comfort "R"**™ mode approved
- Glossy corrosion resistant finish
- Internal high/low pressure and temperature protection
- 018, 024, 030 and 060 ship with start kit
- Liquid line filter-drier
- Tarpaulin gray cabinet with anthracite gray badge & cap
- High pressure switch
- R-410A refrigerant
- S.E.E.T. design testing
- 100% line run test
- Low ambient cooling to 55°F as shipped
- Low ambient cooling to 30°F with AY28X079
- Low ambient cooling to 0°F with BAYLOAM103
- **Extended warranties available**

Contents

Features and Benefits	2
General Data	4
Product Specifications	4
A-weighted Sound Power Level [dB(A)]	4
Accessory Description and Usage	5
ARI Standard Capacity Rating Conditions	5
Model Nomenclature	6
Electrical Data	7
Dimensions	10
Mechanical Specification Options	11



General Data

Product Specifications

Model No. ①	4TTR3018A1	4TTR3024A1	4TTR3030A1	4TTR3036B1
Electrical Data V/Ph/Hz ②	200/230/1/60	200/230/1/60	200/230/1/60	208/230/1/60
Min Cir Ampacity	9	12	15	18
Max Fuse Size (Amps)	15	20	25	30
Compressor	CLIMATUFF®	CLIMATUFF®	CLIMATUFF®	CLIMATUFF®
RL Amps - LR Amps	6.4 - 38.6	8.8 - 57.8	11.1 - 63	13.9 - 71.8
Outdoor Fan FL Amps	0.7	0.7	0.7	0.7
Fan HP	1/8	1/8	1/8	1/8
Fan Dia (inches)	23.0	23.0	23.0	23.0
Coil	Spine Fin™	Spine Fin™	Spine Fin™	Spine Fin™
Refrigerant R-410A	5/04-LB/OZ	5/10-LB/OZ	5/11-LB/OZ	7/14-LB/OZ
Line Size - (in.) O.D. Gas ③	1/2	5/8	3/4	3/4
Line Size - (in.) O.D. Liquid ③	1/4	5/16	5/16	3/8
Charge Spec. Subcooling	10°	10°	10°	12°
Dimensions H x W x D (Crated)	38 x 30.1 x 33	38 x 30.1 x 33	38 x 30.1 x 33	42 x 30.1 x 33
Weight - Shipping	223	224	224	219
Weight - Net	195	197	197	190
Start Components	YES	YES	YES	YES
Sound Enclosure	YES	YES	YES	YES
Compressor Sump Heat	NO	NO	NO	NO
Optional Accessories: ④				
Anti-short Cycle Timer	TAYASCT501A	TAYASCT501A	TAYASCT501A	TAYASCT501A
Evaporator Defrost Control	AY28X079	AY28X079	AY28X079	AY28X079
Rubber Isolator Kit	BAYISLT101	BAYISLT101	BAYISLT101	BAYISLT101
Extreme Condition Mounting Kit	BAYECMT001	BAYECMT001	BAYECMT001	BAYECMT001
Start Kit				
Crankcase Heater Kit	BAYCCHT300	BAYCCHT300	BAYCCHT300	BAYCCHT300
Seacoast Kit	BAYSEAC001	BAYSEAC001	BAYSEAC001	BAYSEAC001
Low Ambient Kit	BAYLOAM103	BAYLOAM103	BAYLOAM103	BAYLOAM103
Refrigerant Lineset ⑤	TAYREFLN5*	TAYREFLN6*	TAYREFLN2*	TAYREFLN7*

① Certified in accordance with the Unitary Air-Conditioner equipment certification program which is based on ARI Standard 210/240.

② Calculated in accordance with N.E.C. Only use HACR circuit breakers or fuses.

③ Standard line lengths - 60'. Standard lift - 60' Suction and Liquid line.

For Greater lengths and lifts refer to refrigerant piping software Pub# 32-3312-0'. (*denotes latest revision)

④ For accessory description and usage, see page 5.

⑤ * = 15, 20, 25, 30, 40 and 50 foot lineset available.

A-weighted Sound Power Level [dB(A)]

MODEL	SOUND POWER LEVEL [dB(A)]	A-WEIGHTED FULL OCTAVE SOUND POWER LEVEL dB - [dB(A)]							
		63	125	250	500	1000	2000	4000	8000
4TTR3018A1	76	47.5	60.4	63	70.3	69.8	69.3	59.3	50.9
4TTR3024A1	76	47.2	61.1	64.8	70.6	70.7	68.4	57.9	50.6
4TTR3030A1	76	49.3	61.1	66.2	70.3	70	67.4	58	51.6
4TTR3036B1	77	45.5	58.7	59.3	69.7	71.2	71.1	60.3	51.8
4TTR3042A1	76	54.9	58.7	61.6	67.2	69	67.7	60.4	53.7
4TTR3048A1	76	55.8	57	62.4	67.5	70.2	67.4	61.1	54.2
4TTR3060B1	76	51.8	55	64	67.7	73.5	65.5	60.2	52.3

Note: Rated in accordance with AHRI Standard 270-2008

General Data

Product Specifications

Model No. ①	4TTR3042A1	4TTR3048A1	4TTR3060B1
Electrical Data V/Ph/Hz ②	208/230/1/60	208/230/1/60	208/230/1/60
Min Cir Ampacity	25	27	34
Max Fuse Size (Amps)	40	45	60
Compressor	CLIMATUFF® - SCROLL	CLIMATUFF® - SCROLL	CLIMATUFF® - SCROLL
RL Amps - LR Amps	18.6 - 105	20.5 - 109	27.6 - 135
Outdoor Fan FL Amps	1.3	1.3	1.3
Fan HP	1/4	1/4	1/4
Fan Dia (inches)	27.6	27.6	27.6
Coil	Spine Fin™	Spine Fin™	Spine Fin™
Refrigerant R-410A	7/00-LB/OZ	7/04-LB/OZ	8/06-LB/OZ
Line Size - (in.) O.D. Gas ③	3/4	7/8	7/8
Line Size - (in.) O.D. Liquid ③	3/8	3/8	3/8
Charge Spec. Subcooling	13°	10°	10°
Dimensions H x W x D (Crated)	38.4 x 35.1 x 38.7	38.4 x 35.1 x 38.7	46.4 x 35.1 x 38.7
Weight - Shipping	258	261	287
Weight - Net	225	227	251
Start Components	NO	NO	YES
Sound Enclosure	NO	NO	NO
Compressor Sump Heat	NO	NO	YES
Optional Accessories: ④			
Anti-short Cycle Timer	TAYASCT501A	TAYASCT501A	TAYASCT501A
Evaporator Defrost Control	AY28X079	AY28X079	AY28X079
Rubber Isolator Kit	BAYISLT101	BAYISLT101	BAYISLT101
Extreme Condition Mounting Kit	BAYECMT001	BAYECMT001	BAYECMT001
Start Kit	BAYKSKT260	BAYKSKT260	
Crankcase Heater Kit	BAYCCHT301	BAYCCHT301	
Seacoast Kit	BAYSEAC001	BAYSEAC001	BAYSEAC001
Low Ambient Kit	BAYLOAM103	BAYLOAM103	BAYLOAM103
Refrigerant Lineset ⑤	TAYREFLN7*	TAYREFLN3*	TAYREFLN3*

Accessory Description and Usage

Anti-Short Cycle Timer — Solid state timing device that prevents compressor recycling until five (5) minutes have elapsed after satisfying call or power interruptions. Use in area with questionable power delivery, commercial applications, long lineset, etc.

Evaporator Defrost Control — SPST Temperature actuated switch that cycles the condenser off as indoor coil reaches freeze-up conditions. Used for low ambient cooling to 30°F with TXV.

Rubber Isolators — Five (5) large rubber donuts to isolate condensing unit from transmitting energy into mounting frame or pad. Use on any application where sound transmission needs to be minimized.

Hard Start kit — Start capacitor and relay to assist compressor motor startup. Use in areas with marginal power supply, on long linesets, low ambient conditions, etc.

Extreme Condition Mount Kit — Bracket kits to securely mount condensing unit to a frame or pad without removing any panels. Use in areas with high winds, or on commercial roof tops, etc.

ARI Standard Capacity Rating Conditions

ARI STANDARD 210/240 RATING CONDITIONS —

- (A) Cooling 80°F DB, 67°F WB air entering indoor coil, 95°F DB air entering outdoor coil.
- (B) High Temperature Heating 47°F DB, 43°F WB air entering outdoor coil, 70°F DB air entering indoor coil.
- (C) Low Temperature Heating 17°F DB, 15°F WB air entering outdoor coil, 70°F DB air entering indoor coil.
- (D) Rated indoor airflow for heating is the same as for cooling.

ARI STANDARD 270 RATING CONDITIONS — (Noise rating numbers are determined with the unit in cooling operation.) Standard Noise Rating number is at 95°F outdoor air.



ARI Standard
210/240 UAC





Model Nomenclature

Outdoor Units

4 T T R 3 0 3 6 B 1 0 0 0 A

- Refrigerant Type
2 = R-22
4 = R-410A
- TRANE
- Product Type
W = Split Heat Pump
T = Split Cooling
- Product Family
Z = Leadership – Two Stage
X = Leadership
R = Replacement/Retail
B = Basic
A = Light Commercial
- Family SEER
0 = 10 3 = 13 6 = 16
1 = 11 4 = 14 8 = 18
2 = 12 5 = 15 9 = 19
- Split System Connections 1-6 Tons
0 = Brazed
- Nominal Capacity in 000s of BTUs
- Major Design Modifications
- Power Supply
1 = 200-230/1/60 or 208-230/1/60
3 = 200-230/3/60
4 = 460/3/60
- Secondary Function
- Minor Design Modifications
- Unit Parts Identifier

High Efficiency Furnaces

T U D 1 B 0 8 0 A 9 H 3 1 A A

- Furnace Configuration
TU = Upflow / Horizontal
TD = Downflow / Horizontal
- Type
D = 80% Premium
X = 90% Premium
- Number of Heating Stages
1 = Single Stage
2 = Two Stage
3 = Three Stage
- Cabinet Width
A = 14.5" Cabinet Width
B = 17.5" Cabinet Width
C = 21.0" Cabinet Width
D = 24.5" Cabinet Width
- Heating Input
080 = 80,000 BTUH
- Major Design Change
- Power Supply / Fuel
9 = 115 Volts / Natural Gas
F = 115 Volts / Natural Gas with Integrated iFD Filter
- Airflow Capacity for Cooling
36 = 3 Ton Standard PSC Motor
H3 = 3 Ton High Efficiency Motor
V3 = 3 Ton Variable Speed Motor
- Draft Inducer Speeds
1 = Single Speed
2 = Two Speed
V = Variable Speed
- Minor Design Change
- Service Digit – Not Orderable

Air Handlers- Residential

1 2 3 4 5 6 7 8 9 10 11 12 13 14 15
4 T E 3 F 3 6 A 1 0 0 0 A A

- Refrigerant Type
4 = R-410A
- Application
TE = Fully Convertible
TG = Semi Convertible
TF = Front Return
TB = Modular Blower
- Product Family
E = Leadership - Variable Speed
H = High Efficiency
C = Replacement/Retail
B = Basic
- Flow Control
0 = No Flow Control
3 = TXV-Non-bleed
- Feature Identifier
0 = Standard Unit
F = Air-Tite™
D = Intergated Whole Home Air Cleaner
C = Communicating Air Handler
- Nominal Capacity in 1000's (BTUH)
- Major Design Change
- Power Supply
1 = Single Phase
- Electrical Connection
0 = Pig Tails
B = Circuit Breaker
D = Pull Disconnect
- Future Option - Factory Installed Heater Nominal KW Value
- Minor Design Change
- Service Digit - Not Orderable

Heat Pump / Cooling Coils

2 T X C B 0 3 6 A C 3 H C A A

- Refrigerant Type
2 = R-22 4 = R-410A
- Product Family
T = Premium (Heat Pump or Convertible Coil)
C = Standard (Cooling Only)
- Coil Design
X = Direct Expansion Evaporator Coil
- Product Family
C = Cased A Coil
A = Uncased A Coil
F = Cased Horizontal Flat Coil
- Coil Width (Cased / Uncased)
A = 14.5" / 13.3" C = 21.0" / 19.8" H = 10.5"
B = 17.5" / 16.3" D = 24.5" / 23.3"
- Refrigerant Line Coupling
0 = Brazed
- Nominal Capacity in 000s of BTUs
- Major Design Change
- Efficiency
C = Standard S = Hi Efficiency
- Refrigerant Control
3 = TXV - Non-Bleed
- Coil Circuitry
H = Heat Pump
C = Cooling Only
- Airflow Configuration
A = Upflow Only
U = Upflow / Downflow
H = Horizontal Only
C = Convertible – Upflow, Downflow, Left Airflow
M = Convertible – Upflow, Downflow, Left or Right Airflow
- Minor Design Change
- Unit Parts Identifier

Electrical Data

SCHEMATIC DIAGRAMS

(SEE LEGEND)

4TTR3018,024,030A1, 036B1

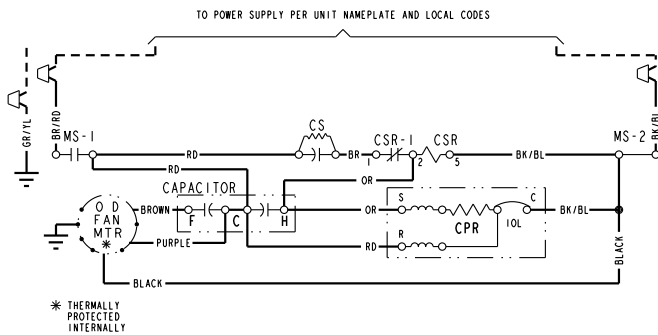

4TTR3042A1

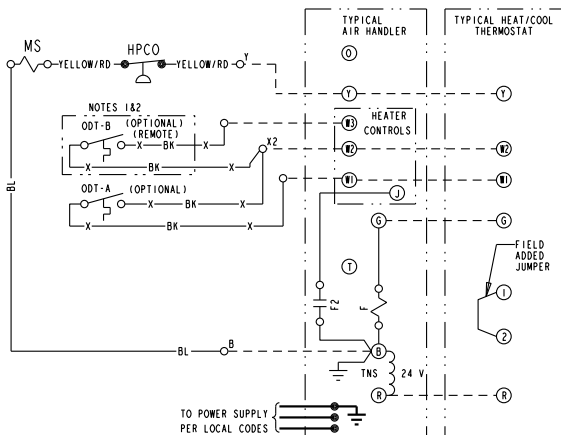
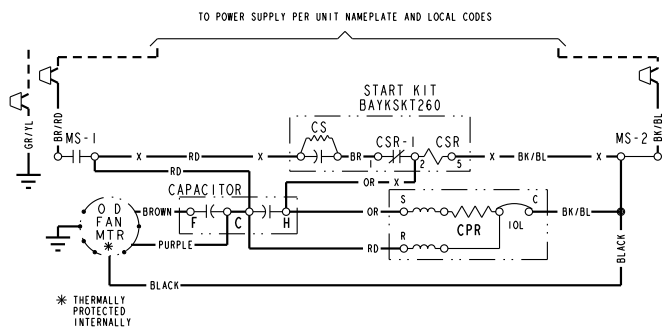

NOTES:

- IF ODT-B IS NOT USED, ADD JUMPER BETWEEN W2 & W3 AT AIR HANDLER. IF USED, ODT-B MUST BE MOUNTED REMOTE OF CONTROL BOX IN AN APPROVED WEATHER PROOF ENCLOSURE.
- IF ODT-A IS NOT USED, ADD JUMPER BETWEEN W1 & W2 AT AIR HANDLER.
- LOW VOLTAGE (24 V.) FIELD WIRING MUST BE 18 AWG MIN.

<p>⚠ WARNING HAZARDOUS VOLTAGE! DISCONNECT ALL ELECTRIC POWER INCLUDING REMOTE DISCONNECTS BEFORE SERVICING. FAILURE TO DISCONNECT POWER BEFORE SERVICING CAN CAUSE SEVERE PERSONAL INJURY OR DEATH!</p>	<p>⚠ CAUTION USE COPPER CONDUCTORS ONLY! UNIT TERMINALS ARE NOT DESIGNED TO ACCEPT OTHER TYPES OF CONDUCTORS. FAILURE TO DO SO MAY CAUSE DAMAGE TO THE EQUIPMENT!</p>
---	--

FOR CANADIAN INSTALLATIONS
POUR INSTALLATIONS CANADIENNES

CAUTION: NOT SUITABLE FOR USE ON SYSTEMS EXCEEDING 150V-TO-GROUND.
ATTENTION: NE CONVIENT PAS AUX INSTALLATIONS DE PLUS DE 150 V A LA TERRE.

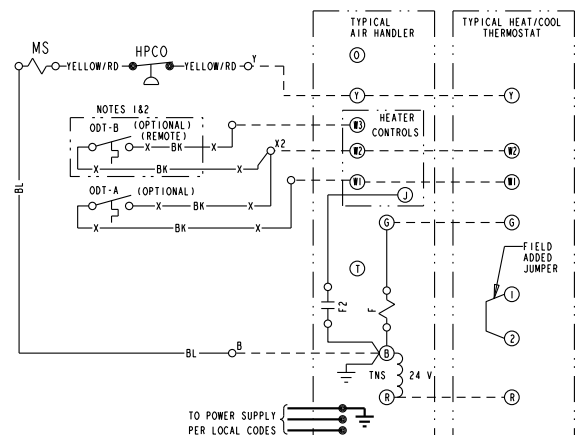

NOTES:

- IF ODT-B IS NOT USED, ADD JUMPER BETWEEN W2 & W3 AT AIR HANDLER. IF USED, ODT-B MUST BE MOUNTED REMOTE OF CONTROL BOX IN AN APPROVED WEATHER PROOF ENCLOSURE.
- IF ODT-A IS NOT USED, ADD JUMPER BETWEEN W1 & W2 AT AIR HANDLER.
- LOW VOLTAGE (24 V.) FIELD WIRING MUST BE 18 AWG MIN.

<p>⚠ WARNING HAZARDOUS VOLTAGE! DISCONNECT ALL ELECTRIC POWER INCLUDING REMOTE DISCONNECTS BEFORE SERVICING. FAILURE TO DISCONNECT POWER BEFORE SERVICING CAN CAUSE SEVERE PERSONAL INJURY OR DEATH!</p>	<p>⚠ CAUTION USE COPPER CONDUCTORS ONLY! UNIT TERMINALS ARE NOT DESIGNED TO ACCEPT OTHER TYPES OF CONDUCTORS. FAILURE TO DO SO MAY CAUSE DAMAGE TO THE EQUIPMENT!</p>
---	--

FOR CANADIAN INSTALLATIONS
POUR INSTALLATIONS CANADIENNES

CAUTION: NOT SUITABLE FOR USE ON SYSTEMS EXCEEDING 150V-TO-GROUND.
ATTENTION: NE CONVIENT PAS AUX INSTALLATIONS DE PLUS DE 150 V A LA TERRE.



Electrical Data

SCHEMATIC DIAGRAMS

(SEE LEGEND)

4TTR3048A1

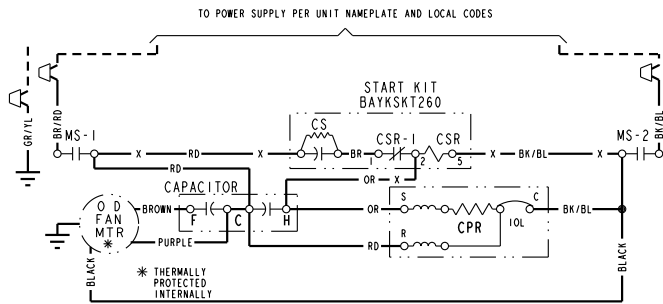

4TTR3060B1

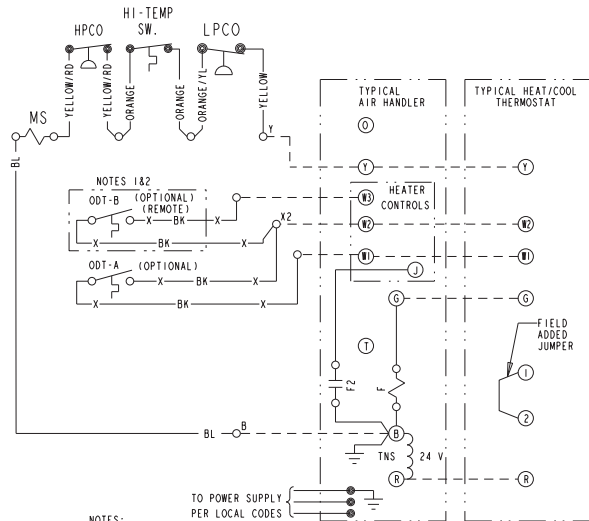
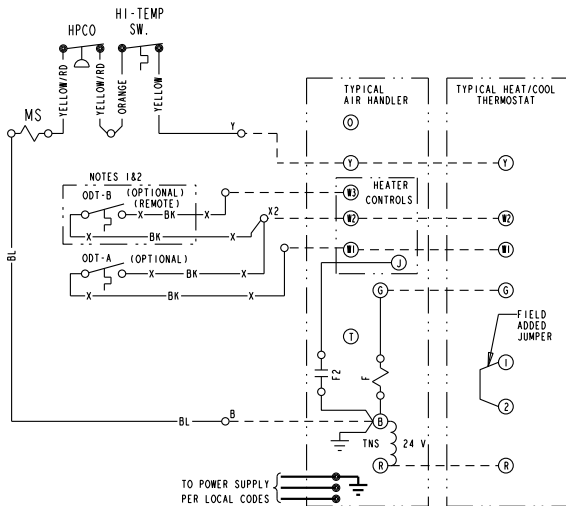
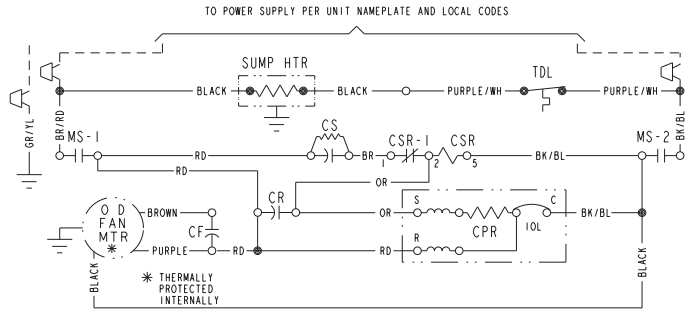

NOTES:

1. IF ODT-B IS NOT USED, ADD JUMPER BETWEEN W2 & W3 AT AIR HANDLER.
IF USED, ODT-B MUST BE MOUNTED REMOTE OF CONTROL BOX IN AN APPROVED WEATHER PROOF ENCLOSURE.
2. IF ODT-A IS NOT USED, ADD JUMPER BETWEEN W1 & W2 AT AIR HANDLER.
3. LOW VOLTAGE (24 V.) FIELD WIRING MUST BE 18 AWG MIN.

NOTES:

1. IF ODT-B IS NOT USED, ADD JUMPER BETWEEN W2 & W3 AT AIR HANDLER.
IF USED, ODT-B MUST BE MOUNTED REMOTE OF CONTROL BOX IN AN APPROVED WEATHER PROOF ENCLOSURE.
2. IF ODT-A IS NOT USED, ADD JUMPER BETWEEN W1 & W2 AT AIR HANDLER.
3. LOW VOLTAGE (24 V.) FIELD WIRING MUST BE 18 AWG MIN.

<p>⚠ WARNING HAZARDOUS VOLTAGE! DISCONNECT ALL ELECTRIC POWER INCLUDING REMOTE DISCONNECTS BEFORE SERVICING. FAILURE TO DISCONNECT POWER BEFORE SERVICING CAN CAUSE SEVERE PERSONAL INJURY OR DEATH!</p>	<p>⚠ CAUTION USE COPPER CONDUCTORS ONLY! UNIT TERMINALS ARE NOT DESIGNED TO ACCEPT OTHER TYPES OF CONDUCTORS. FAILURE TO DO SO MAY CAUSE DAMAGE TO THE EQUIPMENT!</p>
---	--

<p>⚠ WARNING HAZARDOUS VOLTAGE! DISCONNECT ALL ELECTRIC POWER INCLUDING REMOTE DISCONNECTS BEFORE SERVICING. FAILURE TO DISCONNECT POWER BEFORE SERVICING CAN CAUSE SEVERE PERSONAL INJURY OR DEATH!</p>	<p>⚠ CAUTION USE COPPER CONDUCTORS ONLY! UNIT TERMINALS ARE NOT DESIGNED TO ACCEPT OTHER TYPES OF CONDUCTORS. FAILURE TO DO SO MAY CAUSE DAMAGE TO THE EQUIPMENT!</p>
---	--



FOR CANADIAN INSTALLATIONS
POUR INSTALLATIONS CANADIENNES
CAUTION: NOT SUITABLE FOR USE ON SYSTEMS EXCEEDING 150V-TO-GROUND.
ATTENTION: NE CONVIENT PAS AUX INSTALLATIONS DE PLUS DE 150 V A LA TERRE.

FOR CANADIAN INSTALLATIONS
POUR INSTALLATIONS CANADIENNES
CAUTION: NOT SUITABLE FOR USE ON SYSTEMS EXCEEDING 150V-TO-GROUND.
ATTENTION: NE CONVIENT PAS AUX INSTALLATIONS DE PLUS DE 150 V A LA TERRE.





















Electrical Data

SCHEMATIC DIAGRAMS

LEGEND

	COLOR OF WIRE		
BK/BL	BLACK WIRE WITH BLUE MARKER		
	COLOR OF MARKER		
BK	BLACK	OR	ORANGE
BL	BLUE	RD	RED
BR	BROWN	WH	WHITE
		YL	YELLOW
		GR	GREEN
		PR	PURPLE

SYMBOLS

	24 V.	}	FACTORY WIRING
	LINE V.		
	24 V.	}	FIELD WIRING
	LINE V.		
	FIELD INSTALLED FACTORY WIRING		
	GROUND		
	JUNCTION		
	WIRE NUT OR CONNECTOR		
	COIL		
	CAPACITOR		
	RELAY CONTACT (N.O.)		
	RELAY CONTACT (N.C.)		
	THERMISTOR		
	INTERNAL OVERLOAD PROTECTOR		
	PRESSURE ACTUATED SWITCH		
	TEMP. ACTUATED SWITCH		
	POL. PLUG FEMALE HOUSING (MALE TERM.)		
	POL. PLUG MALE HOUSING (FEMALE TERM.)		
	RESISTOR OR HEATING ELEMENT		
	MOTOR WINDING		
	TERMINAL		

CA	COOLING ANTICIPATOR	LPCO	LOW PRESSURE CUTOFF SW.
CBS	COIL BOTTOM SENSOR	MS	COMPRESSOR MOTOR CONTACTOR
CF	FAN CAPACITOR	ODA	OUTDOOR ANTICIPATOR
CN	WIRE CONNECTOR	OFT	OUTDOOR FAN THERMOSTAT
CPR	COMPRESSOR	ODS	OUTDOOR TEMPERATURE SENSOR
CR	RUN CAPACITOR	ODT	OUTDOOR THERMOSTAT
CS	STARTING CAPACITOR	RHS	RESISTANCE HEAT SWITCH
CSR	CAPACITOR SWITCHING RELAY	SC	SWITCHOVER VALVE SOLENOID
DFC	DEFROST CONTROL	SM	SYSTEM "ON-OFF" SWITCH
F	INDOOR FAN RELAY	TDL	DISCHARGE LINE THERMOSTAT
HA	HEATING ANTICIPATOR	TNS	TRANSFORMER
HPCO	HIGH PRESSURE CUTOFF SW.	TS	HEATING-COOLING THERMOSTAT
IOL	INTERNAL OVERLOAD PROTECTOR	TSH	HEATING THERMOSTAT



Dimensions

4TTR3 OUTLINE DRAWING

NOTE: ALL DIMENSIONS ARE IN MM (INCHES)

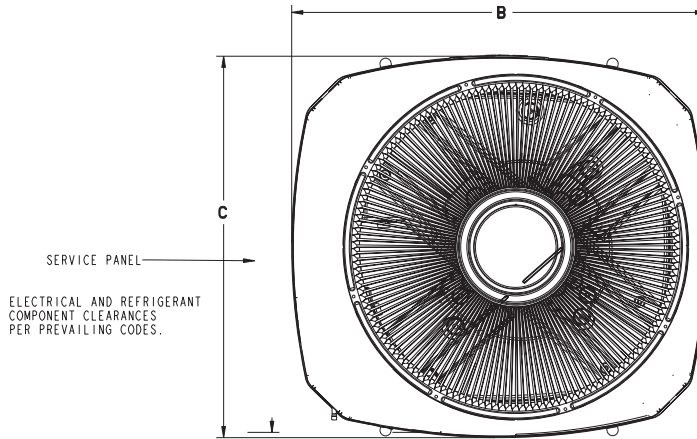

TOP DISCHARGE AREA SHOULD BE UNRESTRICTED FOR AT LEAST 1524 (5 FEET) ABOVE UNIT. UNIT SHOULD BE PLACED SO ROOF RUN-OFF WATER DOES NOT POUR DIRECTLY ON UNIT, AND SHOULD BE AT LEAST 305 (12") FROM WALL AND ALL SURROUNDING SHRUBBERY ON TWO SIDES. OTHER TWO SIDES UNRESTRICTED.

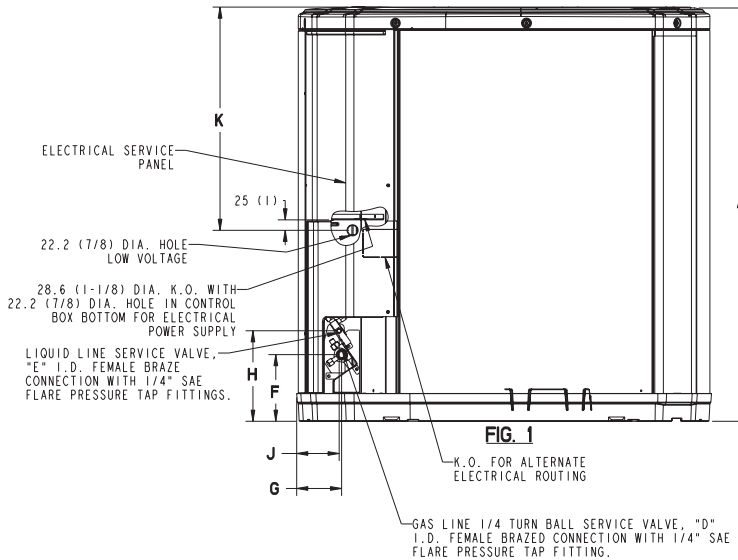

MODELS	BASE	FIG.	A	B	C	D	E	F	G	H	J	K
4TTR3018A	3	1	832 (32-3/4)	829 (32-5/8)	756 (29-3/4)	1/2	3/8	143 (5-5/8)	92 (3-5/8)	210 (8-1/4)	79 (3-1/8)	508 (20)
4TTR3024A	3	1	832 (32-3/4)	829 (32-5/8)	756 (29-3/4)	5/8	3/8	143 (5-5/8)	92 (3-5/8)	210 (8-1/4)	79 (3-1/8)	508 (20)
4TTR3030A	3	1	832 (32-3/4)	829 (32-5/8)	756 (29-3/4)	3/4	3/8	143 (5-5/8)	92 (3-5/8)	210 (8-1/4)	79 (3-1/8)	508 (20)
4TTR3036B	3	1	933 (36-3/4)	829 (32-5/8)	756 (29-3/4)	3/4	3/8	143 (5-5/8)	92 (3-5/8)	210 (8-1/4)	79 (3-1/8)	508 (20)
4TTR3042A	4	1	841 (33-1/8)	946 (37-1/4)	870 (34-1/4)	3/4	3/8	152 (6)	98 (3-7/8)	219 (8-5/8)	86 (3-3/8)	508 (20)
4TTR3048A	4	1	841 (33-1/8)	946 (37-1/4)	870 (34-1/4)	7/8	3/8	152 (6)	98 (3-7/8)	219 (8-5/8)	86 (3-3/8)	508 (20)
4TTR3060A	4	1	1045 (41-1/8)	946 (37-1/4)	870 (34-1/4)	7/8	3/8	152 (6)	98 (3-7/8)	219 (8-5/8)	86 (3-3/8)	508 (20)

From Dwg. DT152898



Mechanical Specification Options

General

The 4TTR3 shall be fully charged from the factory for matched indoor section and up to 15 feet of piping. This unit must be designed to operate at outdoor ambient temperatures as high as 115°F. Cooling capacities shall be matched with a wide selection of air handlers and furnace coils that are ARI certified. The unit is certified to UL 1995. Exterior must be designed for outdoor application.

Casing

Unit casing is constructed of heavy gauge, galvanized steel and painted with a weather-resistant powder paint. Corrosion and weatherproof CMBP-G30 DuraTuff™ base.

Refrigerant Controls

Refrigeration system controls include condenser fan and compressor contactor. High and low pressure controls are inherent to the compressor. Another standard feature is the liquid line dryer.

Compressor

The Climatuff® compressor features internal over temperature and pressure protector, total dipped hermetic motor and thermostatically controlled sump heater. Other features include centrifugal oil pump, and low vibration and noise.

Condenser Coil

The Spine Fin™ coil shall be continuously wrapped, corrosion resistant all aluminum with minimum brazed joints. This coil is 3/8 inch O.D. seamless aluminum glued to a continuous aluminum fin. Coils are lab tested to withstand 2,000 pounds of pressure per square inch. The outdoor coil provides low airflow resistance and efficient heat transfer. The coil is protected on all four sides by louvered panels.

Low Ambient Cooling

As manufactured, this unit has a cooling capability to 55°F. The addition of an evaporator defrost control permits operation to 30°F. The addition of a low ambient kit with TXV permits low ambient cooling to 0°F.

Accessories

Thermostats — Heating/Cooling (manual and automatic changeover). Sub-base to match thermostat and locking thermostat cover.

Evaporator Defrost Control — See Low Ambient Cooling.

Outdoor Thermostat — Supplemental heat outdoor ambient lockout from 46 to -10°F.



ARI StandardTM
210/240 UAC



TRANE[®]

Trane
www.trane.com

07/10

Trane has a policy of continuous product and product data improvement and it reserves the right to change design and specifications without notice.