

Product Data

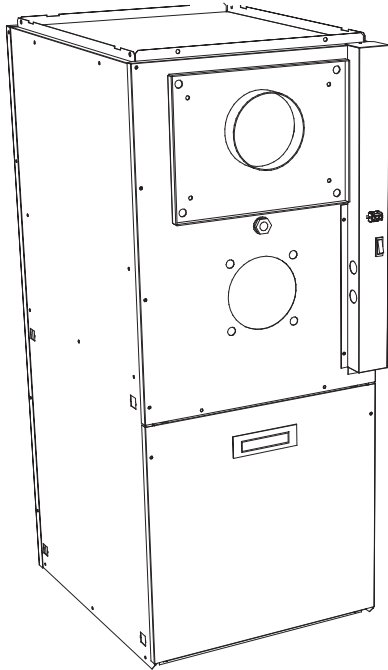

A10311

THE LATEST IN OIL FURNACE TECHNOLOGY

The models OBM and OVM combine high efficiency and quiet operation with oil heating technology. The OBM/OVM can be fired at different rates by a simple nozzle change and oil pump pressure adjustment. Furnaces are available to cover input ranges from 70,000 to 154,000 Btuh. The furnace design is a multipoise style for upflow, downflow, or horizontal applications.

The OBM/OVM is a standard part of a quality-built home. These high efficiency furnaces will provide years of quality service to home builders and homeowners alike.

This model is designed to work as part of a total home comfort system which includes elements for cooling, air cleaning, humidification, ventilation, and zoning.

OBM/OVM FEATURES / BENEFITS

Beckett & Riello Burner Options

- High quality Beckett or Riello oil burners allows safe and efficient combustion of oil.
- Both manufacturers approved for optional Sealed Combustion Venting.
- Ignition control and fan timer board provide reliable operation and easy connection of thermostat and accessory wiring.

Casing

- Made of 22-gauge painted steel for years of durability.

Insulation and Soundproofing

- Unique sound trap along with insulated walls efficiently capture most combustion noise and vibration to make this unit one of the quietest on the market.

Combustion Products Venting

- Front flue outlet.
- Unit may be vented using Type L vent material and a factory-built metal or masonry chimney.
- Unit may also be sidewall vented with optional Sealed Combustion System.
- Unit may also be sidewall vented with an approved power venter.

Adjustable Blower Speed

- OBM units equipped with 4-speed blower for precise airflow selection of heating or cooling operation.
- OVM units equipped with ECM 2.3 Variable Speed high-efficiency motor.

Constant Low-Speed Blower Switch (OBM models)

- Allows continual low-speed air circulation through the home to maximize comfort while maintaining efficiency.
- Air is constantly filtered and stagnant air is avoided.
- This option can be controlled by the homeowner.

Combustion Chamber/Heat Exchanger

- Composed of stainless and aluminized steel, the unique combination combustion chamber/heat exchanger resists corrosion, overheating, and deterioration.
- Heat transfer properties make it highly efficient.
- All seams are tightly welded for leak-free operation.

Certifications

- OBM/OVM units are CSA certified.
- AHRI efficiency rating certified.
- Canada Specifications: Up to 86.7% AFUE for Canada (CSA B212 + Canadian laws)
- USA Specifications: Up to 86.3% AFUE for USA (ASHRAE 103 + American laws)

MODEL NUMBER NOMENCLATURE

OBM/OVM

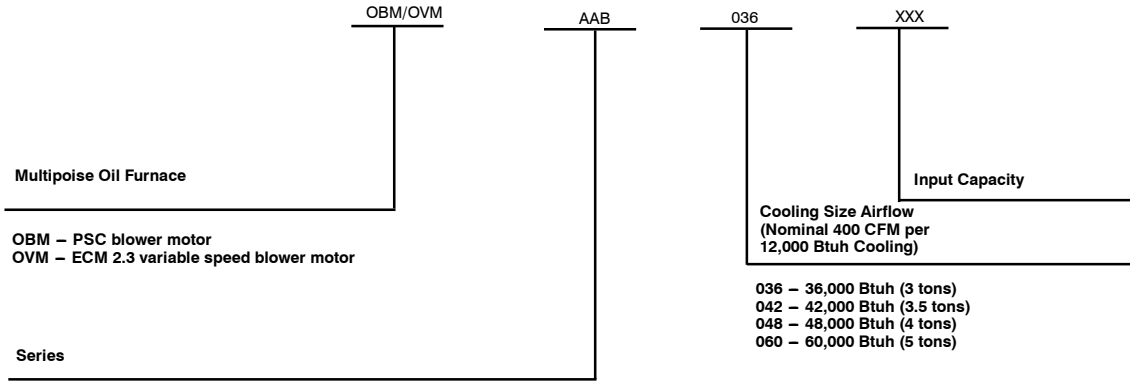

Use of the AHRI Certified TM Mark indicates a manufacturer's participation in the program. For verification of certification for individual products, go to www.ahrirectory.org.

**Always Ask For
FACTORY
AUTHORIZED
PARTS**

CLEARANCE TO COMBUSTIBLES

Location	Application	Upflow In. (mm)	Downflow In. (mm)	Horizontal In. (mm)
Sides	Furnace ¹	1 (25.4)	2 (50.8)	N / A
	Supply plenum – within 6ft (1.8m) of furnace ¹	2 (50.8)	2 (50.8)	1 (25.4)
Bottom	Furnace ² (*use sub-base on combustible floor)	0	2 (50.8) ⁴	1 (25.4) ³
Back	OBM/OVM098 Furnace (opposite end of burner) ¹	3 (76.2)	3 (76.2)	1 (25.4)
	OBM/OVM112 / 154 Furnace (opposite end of burner) ¹	3 (76.2)	3 (76.2)	3 (76.2)
Top	Furnace ² or Plenum	N / A	N / A	2 (50.8)
	Horizontal warm air duct – within 6ft (1.8m) of furnace	2 (50.8)	2 (50.8)	2 (50.8)
Flue pipe	Vertically above flue pipe	9 (228.6)	9 (228.6)	9 (228.6)
Front	Furnace (burner end) ¹	18 (457.2)	18 (457.2)	18 (457.2)

1 Horizontal dimensions

2 Vertical dimensions

3 This dimension can be obtained using Horizontal Flow Base.

4 This dimension can be obtained by using Downflow Base, KLASB0801DET for 098 or KLASB0901DET for 112 or KLASB1001DET for 154.

NON-VARIABLE SPEED UNIT

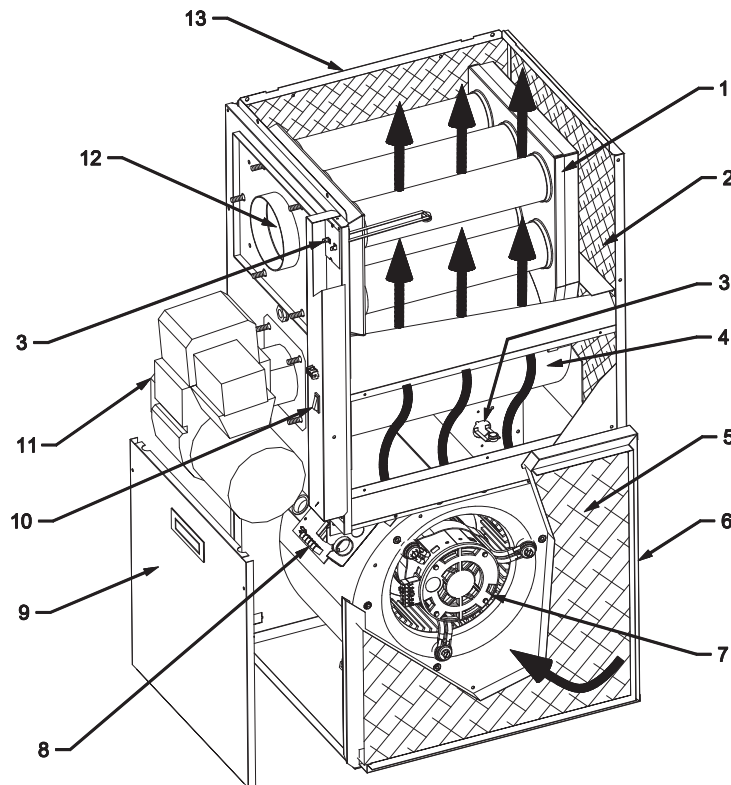

DNS-1254 Rev.A

OBM/OVM

A10309

1. Heat exchanger designed and shaped to efficiently transfer heat from furnace into the home.
2. Fully insulated internal walls to minimize heat loss.
3. High limit control to prevent over temperature.
4. Stainless steel combustion chamber.
5. Air filters.
6. Return-air plenum.
7. Heavy-duty blower circulates air across the heat exchanger to transfer heat into the home.
8. Adjustable electronic fan timer control (inside) has low voltage electrical terminal strip for easy connection of thermostat, cooling control, electronic air cleaner and humidifier.
9. Access doors to air filters and blower.
10. Manual switch to allow user control of constant low-speed blower operation.
11. High-performance oil burner, sold separately.
12. Unique silencer system controls combustion noise.
13. Supply-air plenum.

VARIABLE SPEED UNIT

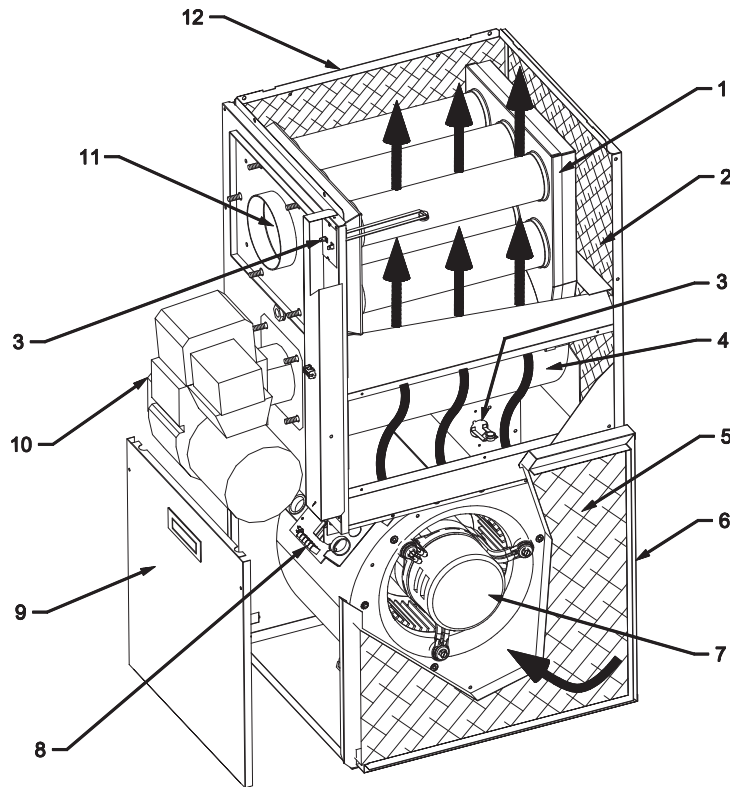

OBM/OVM

1. Heat exchanger designed and shaped to efficiently transfer heat from furnace into the home.
2. Fully insulated internal walls to minimize heat loss.
3. High limit control to prevent over temperature.
4. Stainless steel combustion chamber.
5. Air filters.
6. Return-air plenum.
7. Heavy-duty blower circulates air across the heat exchanger to transfer heat into the home.
8. Adjustable electronic fan timer control (inside) has low voltage electrical terminal strip for easy connection of thermostat, cooling control, electronic air cleaner and humidifier.
9. Access doors to air filters and blower.
10. High-performance oil burner, sold separately.
11. Unique silencer system controls combustion noise.
12. Supply-air plenum.

A10310

FURNACE SPECIFICATIONS

Model:	OVM098			OVM112		OVM154	
Rating & Performance							
Firing rate (USGPH)*	0.50	0.60	0.70	0.68	0.80	0.90	1.10
Input (BTU/h)*	70,000	84,000	98,000	95,200	112,000	126,000	154,000
Maximum heating capacity (BTU/h)*	59,200	70,400	80,800	81,200	94,200	107,000	129,000
Heating temperature rise *	30 – 47°C / 55 – 85°F			33 – 40°C / 60 – 72°F		33 – 40°C / 60 – 72°F	
Flue draft with chimney (in. w.c. / Pa)	–0.06 to –0.025 / –14.9 to –6.2			–0.06 to –0.025 / –14.9 to –6.2		–0.06 to –0.035 / –14.9 to –8.7	
Overfire pressure with chimney (in. w.c. / Pa)	–0.035 to +0.010 / –8.7 to +2.5			–0.035 to +0.025 / –8.7 to +6.2		–0.035 to +0.045 / –8.7 to +11.2	
Flue draft with direct vent (in. w.c. / Pa)	+0.05 to +0.20 / +12.5 to +50			+0.03 to +0.15 / +7.5 to +37.5		+0.05 to +0.16 / +12.5 to +40	
Overfire pressure with direct vent (in. w.c. / Pa)	+0.03 to +0.15 / +7.5 to +37.5			+0.05 to +0.17 / +12.5 to +42.3		+0.06 to +0.22 / +14.9 to +54.8	
Beckett Burner; (Chimney or Direct Vent)							
	KLABR0101BEC			KLABR0201BEC		KLABR0301BEC	
Burner tube insertion length	2–3/4" (70mm)			1–3/4" (45mm)		1–3/4" (45mm)	
Head type	6–slots LQ head			6–slot LQ head		6–slot LC head	
Nozzle (Delavan)	0.40–60A	0.50–60A	0.60–60A	0.60 – 60A	0.70 – 60A	0.75–60B	0.90–60B
Minimum and Maximum pump pressure (PSIG)*	155–190	145–180	135–170	130–160	130–160	145–175	150–180
(kPa)*	1069–1310	1000–1241	931–1172	896–1103	896–1103	1000–1206	1034–1240
Head/Air setting	0.5	1.5	2.5	1.5	2.5	3.5	4.0
CANADIAN regulations and CSA B212 standard** AFUE %	85.0 ‡	84.2	81.9	85.5 ‡	85.0 ‡	86.7 ‡	85.3 ‡
US regulations and ASHRAE 103 standard AFUE %	85.0 ‡	83.9	81.9	85.2 ‡	85.0 ‡	86.3 ‡	85.0 ‡
Riello Burner; (Chimney)							
	KLABR0101RLO			KLABR0301RLO		KLABR0501RLO	
Burner tube insertion length	2–3/4" (70mm)			2–3/4" (70mm)		2 3/4" (70mm)	
Nozzle (Delavan)	0.40–70A	0.50–70A	0.60–70A	0.60 – 70A	0.70 – 70A	0.75–60A	0.90–70A
Minimum and Maximum pump pressure (PSIG)*	155–190	145–180	135–170	130–160	130–160	145–175	150–180
(kPa)*	1069–1310	1000–1241	931–1172	896–1103	896–1103	1000–1206	1034–1240
Combustion air adjustment (turbulator/damper)	0 / 1.5	0 / 2.5	1 / 3.5	1 / 2.6	2 / 3.1	1.5/2.25	2.5/2.75
CANADIAN regulations and CSA B212 standard** AFUE %	85.0 ‡	84.3	81.9	85.5 ‡	85.0 ‡	86.7 ‡	85.3 ‡
US regulations and ASHRAE 103 standard AFUE %	85.0 ‡	83.9	81.9	85.2 ‡	85.0 ‡	86.3 ‡	85.0 ‡
Riello Burner; (Direct Vent)							
	KLABR0201RLO			KLABR0401RLO		KLABR0601RLO	
Burner tube insertion length	2–3/4" (70mm)			2–3/4" (70mm)		2 3/4" (70mm)	
Nozzle (Delavan)	0.40–70A	0.50–70A	0.60–70A	0.60 – 70A	0.70 – 70A	0.75–70A	0.90–70A
Minimum and maximum Pump pressure (PSIG)*	155–190	145–180	135–170	130–160	130–160	145–175	150–180
(kPa)*	1069–1310	1000–1241	931–1172	896–1103	896–1103	1000–1206	1034–1240
Combustion air adjustment (turbulator/damper)	0 / 3.25	0 / 4	1 / 5.25	0 / 2.75	0 / 3.25	1.0/3.75	3.0/4.25
CANADIAN regulations and CSA B212 standard** AFUE %	85.0 ‡	84.3	81.9	85.5 ‡	85.0 ‡	86.7 ‡	85.3 ‡
US regulations and ASHRAE 103 standard AFUE %	85.0 ‡	83.9	81.9	85.2 ‡	85.0 ‡	86.3 ‡	85.0 ‡
Electrical System							
Volts – Hz – Phase	115 – 60 – 1			115 – 60 – 1		115 – 60 – 1	
Rated current (Amps)	10.3			10.3		15.7	
Minimum ampacity for wire sizing (Amps)	12.2			12.2		18.1	
Max. fuse size (Amps)	15			15		20	
Control Transformer (VA)	40			40		40	
External control power available	Heating (VA)	40			40		40
	Cooling (VA)	30			30		30
Blower Data (Side Air Return)							
Motor (HP) / Number of speeds	1/2 HP / ECM			1/2 HP / ECM		1 HP / ECM	
Blower wheel size in(mm)	10 x 8 (254 x 203)			10 x 10 (254 x 254) (tight housing)		12 x 10 (304 x 254)	
General Information							
Overall dimensions W x D x H – in(mm)	16–7/8 x 21–1/8 x 40–3/4 (429 x 511 x 1035)			21–3/4 x 25–3/4 x 41–1/2 (553 x 654 x 1054)		25 x 28–1/2 x 47–7/8 (635 x 724 x 1216)	
Supply air opening – in(mm)	16 x 19 (406 x 483)			17–1/2 x 19 (445 x 483)		20 x 22 (508 x 559)	
Return air opening – in(mm)	19 x 19 (483 x 483)			23 x 19 (584 x 483)		23 x 23 (584 x 584)	
Filter size – in(mm)	20 x 20 (508 x 508)			24 x 20 x 1 (610 x 508 x 25)		24 x 24 x 1 (610 x 610 x 25)	
Shipping weight – lbs(kg)	125 (57)			153 (70)		200 (90)	
Air conditioning, maximum output (tons) at .50 in. w.c. (125 Pa)	3			3.5		5.0	

OBM/OVM

See notes at end of table.

FURNACE SPECIFICATIONS (CONTINUED)

OBM/OVM

Model:	OBM098			OBM112		OBM154	
Rating & Performance							
Firing rate (USGPH)*	0.50	0.60	0.70	0.68	0.80	0.90	1.10
Input (BTU/h)*	70,000	84,000	98,000	95,200	112,000	126,000	154,000
Maximum heating capacity (BTU/h)*	59,200	70,400	80,800	81,200	94,200	107,000	129,000
Heating temperature rise *	31 – 47°C / 55 – 85°F			31 – 42°C / 55 – 75°F		31 – 42°C / 55 – 75°F	
Flue draft with chimney (in. w.c. / Pa)	-0.06 to -0.025 / -14.9 to -6.2			-0.06 to -0.025 / -14.9 to -6.2		-0.06 to -0.035 / -14.9 to -8.7	
Overfire pressure with chimney (in. w.c. / Pa)	-0.035 to +0.010 / -8.7 to +2.5			-0.035 to +0.025 / -8.7 to +6.2		-0.035 to +0.045 / -8.7 to +11.2	
Flue draft with direct vent (in. w.c. / Pa)	+0.05 to +0.20 / +12.5 to +50			+0.03 to +0.15 / +7.5 to +37.5		+0.05 to +0.16 / +12.5 to +40	
Overfire pressure with direct vent (in. w.c. / Pa)	+0.03 to +0.15 / +7.5 to +37.5			+0.05 to +0.17 / +12.5 to +42.3		+0.06 to +0.22 / +14.9 to +54.8	
Beckett Burner, Chimney or Direct Vent							
	KLABR0101BEC			KLABR0201BEC		KLABR0301BEC	
Burner tube insertion length	2-3/4" (70mm)			1-3/4" (45mm)		1-3/4" (45mm)	
Head type	6-slot LQ head			6-slot LQ head		6-slot LC head	
Nozzle (Delavan)	0.40-60A	0.50-60A	0.60-60A	0.60-60A	0.70-60A	0.75-60B	0.90-60B
Minimum and Maximum pump pressure (PSIG)*	155-190	145-180	135-170	130-160	130-160	145-175	150-180
(kPa)*	1069-1310	1000-1241	931-1172	896-1103	896-1103	1000-1206	1034-1240
Head/Air setting	0.5	1.5	2.5	1.5	2.5	3.5	4.0
CANADIAN regulations and CSA B212 standard ** AFUE %	85.0 ‡	84.2	81.9	85.5 ‡	85.0 ‡	86.7 ‡	85.3 ‡
US regulations and ASHRAE 103 standard AFUE %	85.0 ‡	83.9	81.9	85.2 ‡	85.0 ‡	86.3 ‡	85.0 ‡
Riello Burner, Chimney							
	KLABR0101RLO			KLABR0301RLO		KLABR0501RLO	
Burner tube insertion length	2 3/4" (70mm)			2 3/4" (70mm)		2 3/4" (70mm)	
Nozzle (Delavan)	0.40-70A	0.50-70A	0.60-70A	0.60-70A	0.70-70A	0.75-60A	0.90-70A
Minimum and Maximum pump pressure (PSIG)*	155-190	145-180	135-170	130-160	130-160	145-175	150-180
(kPa)*	1069-1310	1000-1241	931-1172	896-1103	896-1103	1000-1206	1034-1240
Combustion air adjustment (turbulator/damper)	0 / 1.5	0 / 2.5	1 / 3.5	1 / 2.6	2 / 3.1	1.5/2.25	2.5/2.75
CANADIAN regulations and CSA B212 standard ** AFUE %	85.0 ‡	84.3	81.9	85.5 ‡	85.0 ‡	86.7 ‡	85.3 ‡
US regulations and ASHRAE 103 standard AFUE %	85.0 ‡	83.9	81.9	85.2 ‡	85.0 ‡	86.3 ‡	85.0 ‡
Riello Burner, Direct Vent							
	KLABR0201RLO			KLABR0401RLO		KLABR0601RLO	
Burner tube insertion length	2 3/4" (70mm)			2 3/4" (70mm)		2 3/4" (70mm)	
Nozzle (Delavan)	0.40-70A	0.50-70A	0.60-70A	0.60-70A	0.70-70A	0.75-70A	0.90-70A
Minimum and maximum Pump pressure (PSIG)*	155-190	145-180	135-170	130-160	130-160	145-175	150-180
(kPa)*	1069-1310	1000-1241	931-1172	896-1103	896-1103	1000-1206	1034-1240
Combustion air adjustment (turbulator/damper)	0 / 3.25	0 / 4	1 / 5.25	0 / 2.75	0 / 3.25	1.0/3.75	3.0/4.25
CANADIAN regulations and CSA B212 standard ** AFUE %	85.0 ‡	84.2	81.9	85.5 ‡	85.0 ‡	86.7 ‡	85.3 ‡
US regulations and ASHRAE 103 standard AFUE %	85.0 ‡	83.9	81.9	85.2 ‡	85.0 ‡	86.3 ‡	85.0 ‡
Electrical System							
Volts - Hz - Phase	115 - 60 - 1			115 - 60 - 1		115 - 60 - 1	
Rated current (Amps)	12.2			12.6		16.9	
Minimum ampacity for wire sizing (Amps)	13.7			15.2		19.5	
Max. fuse size (Amps)	15			20		20	
Control Transformer (VA)	40			40		40	
External control power available	Heating (VA)			40		40	
	Cooling (VA)			30		30	
Blower Data, Side Air Return							
Heating blower speed at 0.25 in. w.c. (62 Pa)	Med-Low	Med-High	High	Med-Low	Med-High	Med-Low	Med-High
Heating blower speed at 0.50 in. w.c. (125 Pa)	Med-Low	Med-High	High	Med-Low	Med-High	Med-Low	Med-High
Heating Air flow at 0.25 in. w.c. (62 Pa) - side air return - CFM(L/s)	850 (401)	1050 (496)	1165 (550)	1180 (597)	1320 (623)	1515 (715)	1875(885)
Cooling Air flow at 0.50 in. w.c. (125 Pa) - side air return - CFM(L/s)	795 (375)	925 (437)	1050 (496)	1080 (510)	1200 (566)	1915(903)	1915(903)
Motor (HP) / Number of speeds	1/3 HP / 4 speeds			1/2 HP / 4 speeds		1 HP / 4 speeds	
Blower wheel size in(mm)	10 x 8 (254 x 203)			10 x 10 (254 x 254) (tight housing)		12 x 10 (304 x 254)	
General Information							
Overall dimensions W x D x H - in(mm)	16-7/8" x 21-1/8" x 40-3/4" (429 x 537 x 1035)			21-3/4" x 25-3/4" x 41-1/2" (553 x 654 x 1054)		25" x 28-1/2" x 47-7/8" (635 x 724 x 1216)	
Supply air opening - in(mm)	16" x 19" (406 x 483)			17-1/2" x 19" (445 x 483)		20" x 22" (508 x 559)	
Return air opening - in(mm)	19" x 19" (483 x 483)			23" x 19" (584 x 483)		23" x 23" (584 x 584)	
Filter size - in(mm)	20" x 20" (508 x 508)			24" x 20" x 1" (610 x 508 x 25)		24" x 24" x 1"	
Shipping weight - lbs(kg)	125 (57)			153 (70)		200 (90)	
Air conditioning, maximum output - tons	2.5			3.5		5.0	

***INPUT & OUTPUT ADJUSTMENT**

Pump pressure can be adjusted to maintain proper firing rate.
 Adjust flue gas temperature between 400 and 575 °F/204 and 301 °C
 Adjust fan speed for air temperature rise of 55 to 85 °F/30 to 47 °C.

**AFUE value established after minimum 20 hours of continuous operation.

‡ Meets EnergyStar guidelines

FURNACE ACCESSORIES

098 SIZE FURNACE ACCESSORIES	
KLABR0101RLO	Riello 40–F3 Burner (0.50–70A nozzle)
KLABR0201RLO	Riello 40–BF3 Burner (0.50–70A nozzle)
KLABR0101BEC	Beckett NX Burner (0.50–60A nozzle)
KLASB0801DET	Downflow Combustible Floor base
KLARB0101DET	Floor Return Base

112 SIZE FURNACE ACCESSORIES	
KLABR0301RLO	Riello 40–F3 Burner (0.60–70A nozzle)
KLABR0401RLO	Riello 40–BF5 Burner (0.60–70A nozzle)
KLABR0201BEC	Beckett NX Burner (0.60–60A nozzle)
KLASB0901DET	Downflow Combustible Floor base

154 SIZE FURNACE ACCESSORIES	
KLABR0501RLO	Riello 40–F3 Burner (0.75–70A nozzle)
KLABR0601RLO	Riello 40–BF5 Burner (0.75–70A nozzle)
KLABR0301BEC	Beckett NX Burner (0.75–60B nozzle)
KLASB1001DET	Downflow Combustible Floor base

COMMON FURNACE ACCESSORIES	
KLABV0201DET	Blocked Vent Shutoff Kit
KLAFV0101DET	Insulated Flex vent 4–in. (101.6 mm) – 10 ft. (3 M) Long
KLAFV0201DET	Insulated Flex vent 4–in. (101.6 mm) – 20 ft. (6 M) Long
KLAVT0101DET	Vent Terminal Kit 4–in. (101.6 mm)
KLASB0701DET	Horizontal Subbase
KLAFV0301DET	Insulated Flex vent 5–in. (127 mm) – 8 ft. (2 M) Long
KLAFV0401DET	Insulated Flex vent 5–in. (127 mm) – 20 ft. (6 M) Long
KLAVT0201DET	Vent Terminal Kit 5–in. (127 mm)

OBM/OVM

AIR DELIVERY - CFM (WITH FILTERS)

OBM098

BLOWER SPEED	EXTERNAL STATIC PRESSURE WITH AIR FILTER (In. W.C.)								
	0.1	0.2	0.3	0.4	0.5	0.6	0.7	0.8	0.9
HIGH	1230 (580)	1185 (559)	1150 (543)	1095 (517)	1050 (496)	990 (467)	920 (434)	810 (382)	595 (281)
MED-HIGH	1090 (514)	1055 (498)	1005 (474)	970 (458)	925 (437)	875 (413)	810 (382)	700 (330)	550 (260)
MED-LOW	865 (408)	860 (406)	860 (406)	845 (399)	795 (375)	740 (349)	695 (328)	600 (283)	460 (217)
LOW	675 (319)	680 (321)	690 (326)	680 (321)	665 (314)	640 (302)	565 (267)	480 (227)	390 (184)

OBM112

OBM/OVM

BLOWER SPEED	EXTERNAL STATIC PRESSURE WITH AIR FILTER (In. W.C.)					
	0.2	0.3	0.4	0.5	0.6	0.7
HIGH	1550 (731)	1510 (713)	1460 (689)	1400 (661)	1320 (623)	1220 (576)
MED-HIGH	1320 (623)	1280 (604)	1240 (585)	1200 (566)	1160 (547)	1020 (481)
MED-LOW	1180 (557)	1150 (543)	1110 (524)	1080 (510)	1040 (491)	940 (444)
LOW	1070 (505)	1040 (491)	1010 (477)	980 (462)	910 (429)	840 (396)

OBM154

BLOWER SPEED	EXTERNAL STATIC PRESSURE WITH AIR FILTER (In. W.C.)					
	0.2	0.3	0.4	0.5	0.6	0.7
HIGH	2130	2085	1995	1915	1820	1745
MED-HIGH	1930	1855	1800	1750	1675	1615
MED-LOW	1565	1495	1460	1430	1400	1360
LOW	1185	1170	1140	1105	1080	1065

AIR DELIVERY - CFM (WITH FILTERS)

OVM098

OIL HEATING MODE - 24 VAC input (R) on W only				
SW1- HEAT DIP switch position	HEAT INPUT (USGPH)	CFM (L/s) with SW3-ADJ DIP switch position A	CFM (L/s) with SW3-ADJ DIP switch position B	CFM (L/s) with SW3-ADJ DIP switch position C
A (1=OFF, 2=OFF)	0.70	1260 (595)	1385 (654)	1135 (536)
B (1=ON, 2=OFF)	0.60	1050 (496)	1155 (545)	945 (446)
C (1=OFF, 2=ON)	0.50	850 (401)	935 (441)	765 (361)
D (1=ON, 2=ON)	Same value as DIP switch position A			

CONTINUOUS FAN - 24 VAC input (R) on G only				
SW2- COOL DIP switch position	A/C size (TON)	CFM (L/s) with SW3-ADJ DIP switch position A	CFM (L/s) with SW3-ADJ DIP switch position B	CFM (L/s) with SW3-ADJ DIP switch position C
A (1=OFF, 2=OFF)	3.0	900 (425)	990 (467)	810 (382)
B (1=ON, 2=OFF)	2.5	750 (354)	830 (392)	675 (319)
C (1=OFF, 2=ON)	2.0	600 (283)	660 (311)	540 (255)
D (1=ON, 2=ON)	1.5	450 (212)	495 (234)	405 (191)

COOLING OR HEAT PUMP HEATING MODE - 24 VAC input (R) to G, Y/Y2 and O (for cooling)				
SW2- COOL DIP switch position	A/C size (TON)	CFM (L/s) with SW3-ADJ DIP switch position A	CFM (L/s) with SW3-ADJ DIP switch position B	CFM (L/s) with SW3-ADJ DIP switch position C
A (1=OFF, 2=OFF)	3.0	1200 (566)	1320 (623)	1080 (510)
B (1=ON, 2=OFF)	2.5	1000 (472)	1100 (519)	900 (425)
C (1=OFF, 2=ON)	2.0	800 (378)	880 (415)	720 (340)
D (1=ON, 2=ON)	1.5	600 (283)	660 (311)	540 (255)

In Cooling - Dehumidification mode, with no 24 VAC input to DH, the CFM (L/s) are reduced by 15%.
The CFM (L/s) shown are reduced by 20% if there is 24 VAC input to Y1 (Slow speed of 2-speed compressor)

DELAY PROFILE FOR OIL HEATING MODE				
SW4- DELAY DIP switch position	HEAT INPUT (USGPH)	PreRun On-Delay CFM (L/s) Level - Time	ShortRun On-Delay CFM (L/s) Level - Time	Off-Delay CFM (L/s) Level - Time
A (1=OFF, 2=OFF)	0.75	13% - 45 sec.	19% - 30 sec	38% -3 min.
B (1=ON, 2=OFF)	0.65	13% - 45 sec.	19% - 60 sec	38% -3 min.
C (1=OFF, 2=ON)	0.50	13% - 60 sec.	13% - 60 sec	38% -3 min.
D (1=ON, 2=ON)	All	13% - 30 sec.	100% - 0 sec	100% - 2 min.

PreRun and ShortRun are the periods of time when the the blower starts at very low CFM (L/s) to minimize the distribution of cool air in the system and then runs up to normal speed.
Off Delay is the time required to cool down the heat exchanger with low CFM (L/s), to minimize cool draft in the air distribution system.

DELAY PROFILE FOR COOLING OR HEAT PUMP HEATING MODE				
No adjustment required	A/C size	PreRun On-Delay CFM (L/s) Level - Time	ShortRun On-Delay CFM (L/s) Level - Time	Off-Delay CFM (L/s) Level - Time
-	All	No delay	No delay	100% - 90 sec.

PreRun and ShortRun are the periods of time when the the blower starts at very low CFM (L/s) to minimize the distribution of cool air in the system and then runs up to normal speed.
Off Delay is the time required to cool down the coil (heating mode) with low CFM (L/s), to minimize cool draft in the air distribution system.

OBM/OVM

AIR DELIVERY - CFM (WITH FILTERS)

OVM112

OIL HEATING MODE - 24 VAC input (R) on W only

SW1- HEAT DIP switch position	HEAT INPUT (USGPH)	CFM (L/s) with SW3-ADJ DIP switch position A	CFM (L/s) with SW3-ADJ DIP switch position B	CFM (L/s) with SW3-ADJ DIP switch position C
A (1=OFF, 2=OFF)	0.68	1160 (547)	1310 (618)	990 (467)
B (1=ON, 2=OFF)	0.80	1340 (632)	1400 (661)	1140 (538)
C (1=OFF, 2=ON)*	0.68	1000 (472)	1130 (533)	850 (401)
D (1=ON, 2=ON)*	0.80	1160 (547)	1310 (618)	990 (467)

CONTINUOUS FAN - 24 VAC input (R) on G only

SW2- COOL DIP switch position	A/C size (TON)	CFM (L/s) with SW3-ADJ DIP switch position A	CFM (L/s) with SW3-ADJ DIP switch position B	CFM (L/s) with SW3-ADJ DIP switch position C
A (1=OFF, 2=OFF)	3.5	1050 (496)	1210 (571)	895 (422)
B (1=ON, 2=OFF)	3.0	900 (425)	1035 (488)	765 (361)
C (1=OFF, 2=ON)	2.5	750 (354)	865 (408)	640 (302)
D (1=ON, 2=ON)	2.0	600 (283)	690 (326)	510 (241)

COOLING OR HEAT PUMP HEATING MODE - 24 VAC input (R) to G, Y/Y2 and O (for cooling)

SW2- COOL DIP switch position	A/C size (TON)	CFM (L/s) with SW3-ADJ DIP switch position A	CFM (L/s) with SW3-ADJ DIP switch position B	CFM (L/s) with SW3-ADJ DIP switch position C
A (1=OFF, 2=OFF)	3.5	1400 (661)	1400 (661)	1260 (595)
B (1=ON, 2=OFF)	3.0	1200 (566)	1320 (623)	1080 (510)
C (1=OFF, 2=ON)	2.5	1000 (472)	1100 (519)	900 (425)
D (1=ON, 2=ON)	2.0	800 (378)	880 (415)	720 (340)

In Cooling - Dehumidification mode, with no 24 VAC input to DH, the CFM (L/s) are reduced by 15%.

The CFM (L/s) shown are reduced by 20% if there is 24 VAC input to Y1 (first stage cooling mode)

DELAY PROFILE FOR OIL HEATING MODE

SW4- DELAY DIP switch position	HEAT INPUT (USGPH)	PreRun On-Delay CFM (L/s) Level - Time	ShortRun On-Delay CFM (L/s) Level - Time	Off-Delay CFM (L/s) Level - Time
A (1=OFF, 2=OFF)	0.68	13% - 45 sec.	19% - 60 sec	38% - 3 min.
B (1=ON, 2=OFF)	0.8	13% - 45 sec.	19% - 30 sec	38% - 3 min.
C (1=OFF, 2=ON)	All	13% - 45 sec.	100% - 0 sec	100% - 2 min.
D (1=ON, 2=ON)	All	13% - 90 sec.	100% - 0 sec	100% - 2 min.

PreRun and ShortRun are the periods of time when the the blower starts at very low CFM (L/s) to minimize the distribution of cool air in the system and then runs up to normal speed.

Off Delay is the time required to cool down the heat exchanger with low CFM (L/s), to minimize cool draft in the air distribution system.

DELAY PROFILE FOR COOLING OR HEAT PUMP HEATING MODE

No adjustment required	A/C size	PreRun On-Delay CFM (L/s) Level - Time	ShortRun On-Delay CFM (L/s) Level - Time	Off-Delay CFM (L/s) Level - Time
-	All	No delay	No delay	100% - 90 sec.

PreRun and ShortRun are the periods of time when the the blower starts at very low CFM (L/s) to minimize the distribution of cool air in the system and then runs up to normal speed.

Off Delay is the time required to cool down the coil (heating mode) with low CFM (L/s), to minimize cool draft in the air distribution system.

* Alternate adjustment in oil-fired heating mode with higher temperature rise.

OBM/OVM

AIR DELIVERY - CFM (WITH FILTERS)

OVM154

OIL HEATING MODE - 24 VAC input (R) on W only				
SW1- HEAT DIP switch position	HEAT INPUT (USGPH)	CFM (L/s) with SW3-ADJ DIP switch position A	CFM (L/s) with SW3-ADJ DIP switch position B	CFM (L/s) with SW3-ADJ DIP switch position C
A (1=OFF, 2=OFF)	0.90	1450 (684)	1640 (774)	1235 (583)
B (1=ON, 2=OFF)	1.10	1700 (802)	1920 (906)	1445 (682)
C (1=OFF, 2=ON)*	Settings not used in this mode			
D (1=ON, 2=ON)*				

CONTINUOUS FAN - 24 VAC input (R) on G only				
SW2- COOL DIP switch position	A/C size (TON)	CFM (L/s) with SW3-ADJ DIP switch position A	CFM (L/s) with SW3-ADJ DIP switch position B	CFM (L/s) with SW3-ADJ DIP switch position C
A (1=OFF, 2=OFF)	5.0	1500 (708)	1650 (779)	1350 (637)
B (1=ON, 2=OFF)	4.0	1200 (566)	1320 (623)	1080 (510)
C (1=OFF, 2=ON)	3.5	1050 (496)	1155 (545)	945 (446)
D (1=ON, 2=ON)	3.0	900 (425)	990 (467)	810 (382)

COOLING OR HEAT PUMP HEATING MODE - 24 VAC input (R) to G, Y/Y2 and O (for cooling)				
SW2- COOL DIP switch position	A/C size (TON)	CFM (L/s) with SW3-ADJ DIP switch position A	CFM (L/s) with SW3-ADJ DIP switch position B	CFM (L/s) with SW3-ADJ DIP switch position C
A (1=OFF, 2=OFF)	5.0	2000 (944)	2200 (1038)	1800 (849)
B (1=ON, 2=OFF)	4.0	1600 (755)	1760 (831)	1440 (680)
C (1=OFF, 2=ON)	3.5	1400 (661)	1540 (727)	1260 (595)
D (1=ON, 2=ON)	3.0	1200 (566)	1320 (623)	1080 (510)

In Cooling - Dehumidification mode, with no 24 VAC input to DH, the CFM (L/s) are reduced by 15%.
 The CFM (L/s) shown are reduced by 20% if there is 24 VAC input to Y1 (first stage cooling mode)

DELAY PROFILE FOR OIL HEATING MODE				
SW4- DELAY DIP switch position	HEAT INPUT (USGPH)	PreRun On-Delay CFM (L/s) Level - Time	ShortRun On-Delay CFM (L/s) Level - Time	Off-Delay CFM (L/s) Level - Time
A (1=OFF, 2=OFF)	0.90	13% - 90 sec.	31% - 30 sec.	50% - 4 min.
B (1=ON, 2=OFF)	1.10	13% - 60 sec.	31% - 30 sec.	38% - 5 min.
C (1=OFF, 2=ON)	ALL	13% - 90 sec.	31% - 30 sec.	56% - 5 min.
D (1=OFF, 2=ON)	ALL	13% - 60 sec.	31% - 30 sec.	44% - 5 min.

PreRun and ShortRun are the periods of time when the the blower starts at very low CFM (L/s) to minimize the distribution of cool air in the system and then runs up to normal speed.
 Off Delay is the time required to cool down the heat exchanger with low CFM (L/s), to minimize cool draft in the air distribution system.

DELAY PROFILE FOR COOLING OR HEAT PUMP HEATING MODE				
No adjustment required	A/C size	PreRun On-Delay CFM (L/s) Level - Time	ShortRun On-Delay CFM (L/s) Level - Time	Off-Delay CFM (L/s) Level - Time
-	All	No delay	No delay	100% - 90 sec.

PreRun and ShortRun are the periods of time when the the blower starts at very low CFM (L/s) to minimize the distribution of cool air in the system and then runs up to normal speed.
 Off Delay is the time required to cool down the coil (heating mode) with low CFM (L/s), to minimize cool draft in the air distribution system.

* Alternate adjustment in oil-fired heating mode with higher temperature rise.

OVM/OVM

DIMENSIONS - OBM/OVM098

OBM/OVM

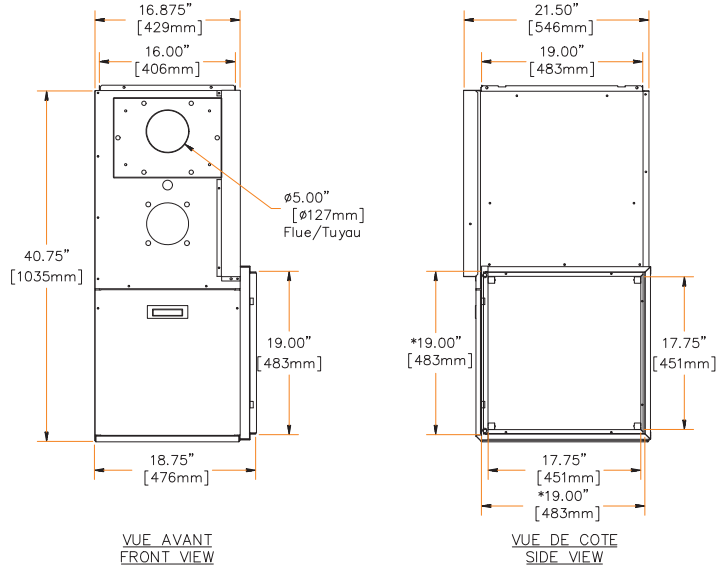

* OUVERTURE CONDUIT/DUCT OPENING

INSTALLATION HORIZONTALE AVEC BASE RETOUR DE PLANCHER
HORIZONTAL INSTALLATION WITH FLOOR RETURN BASE

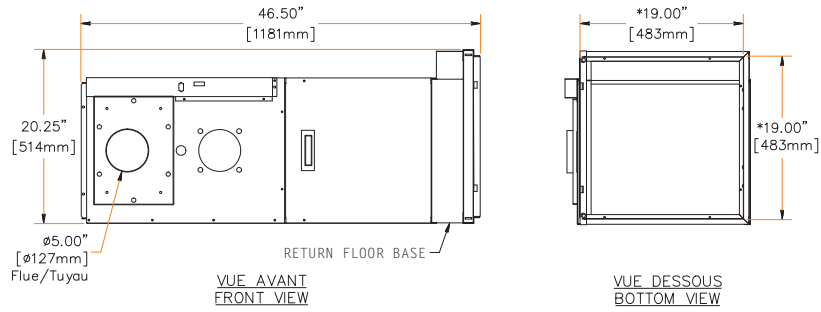

* OUVERTURE CONDUIT/DUCT OPENING

A10316

DIMENSIONS - OBM/OVM112

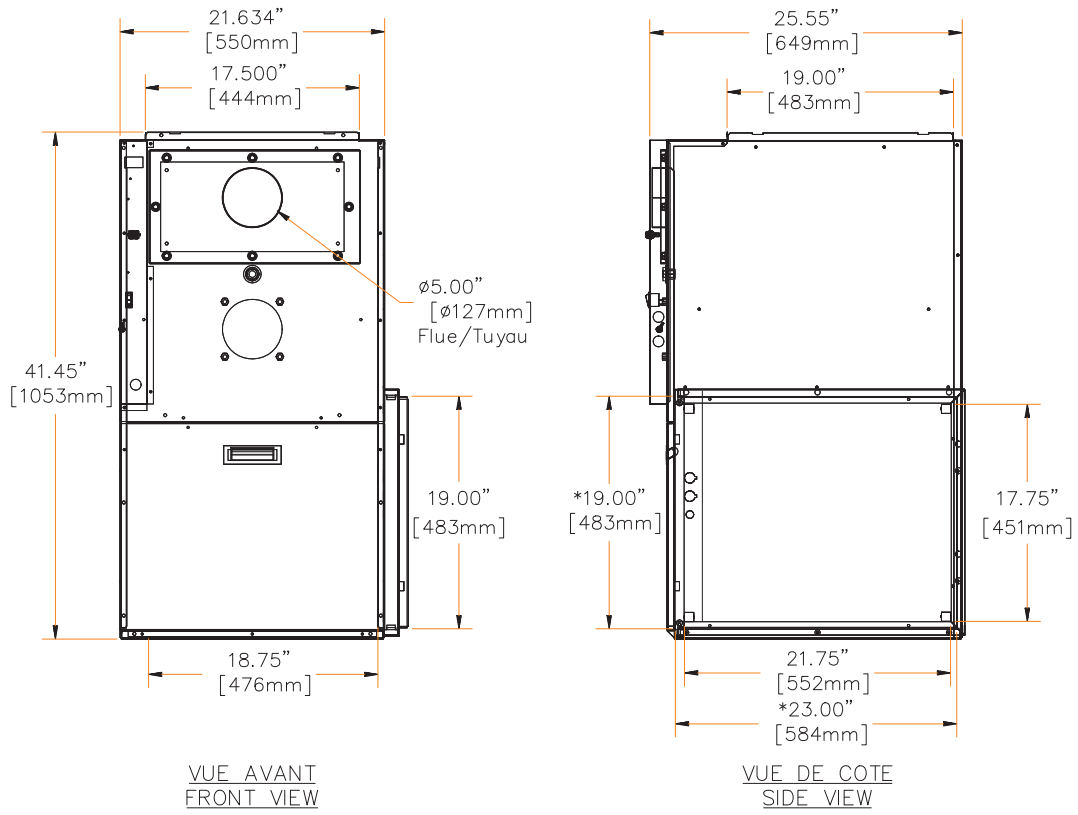

* OUVERTURE CONDUIT/DUCT OPENING

DNS-1226 Rev.A

A10317

DIMENSIONS - OBM/OVM154

OBM/OVM

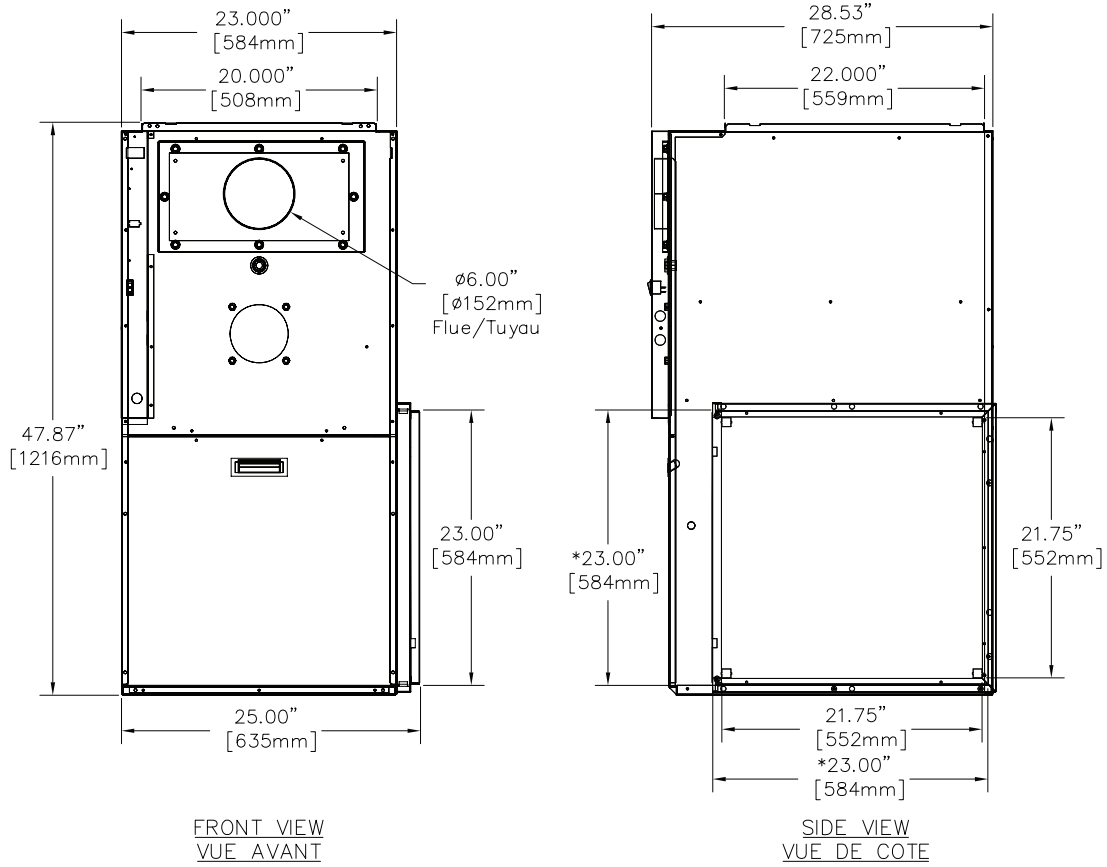

* DUCT OPENING/OUVERTURE CONDUIT

DNS-1290 Rev.B

A11467

TYPICAL INSTALLATION

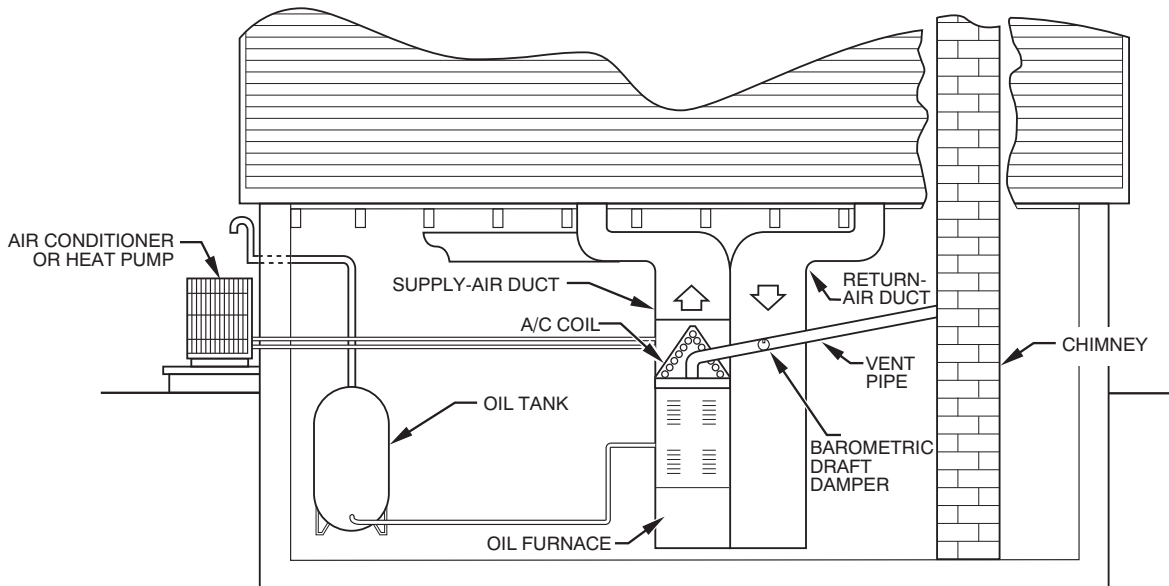

A10322