

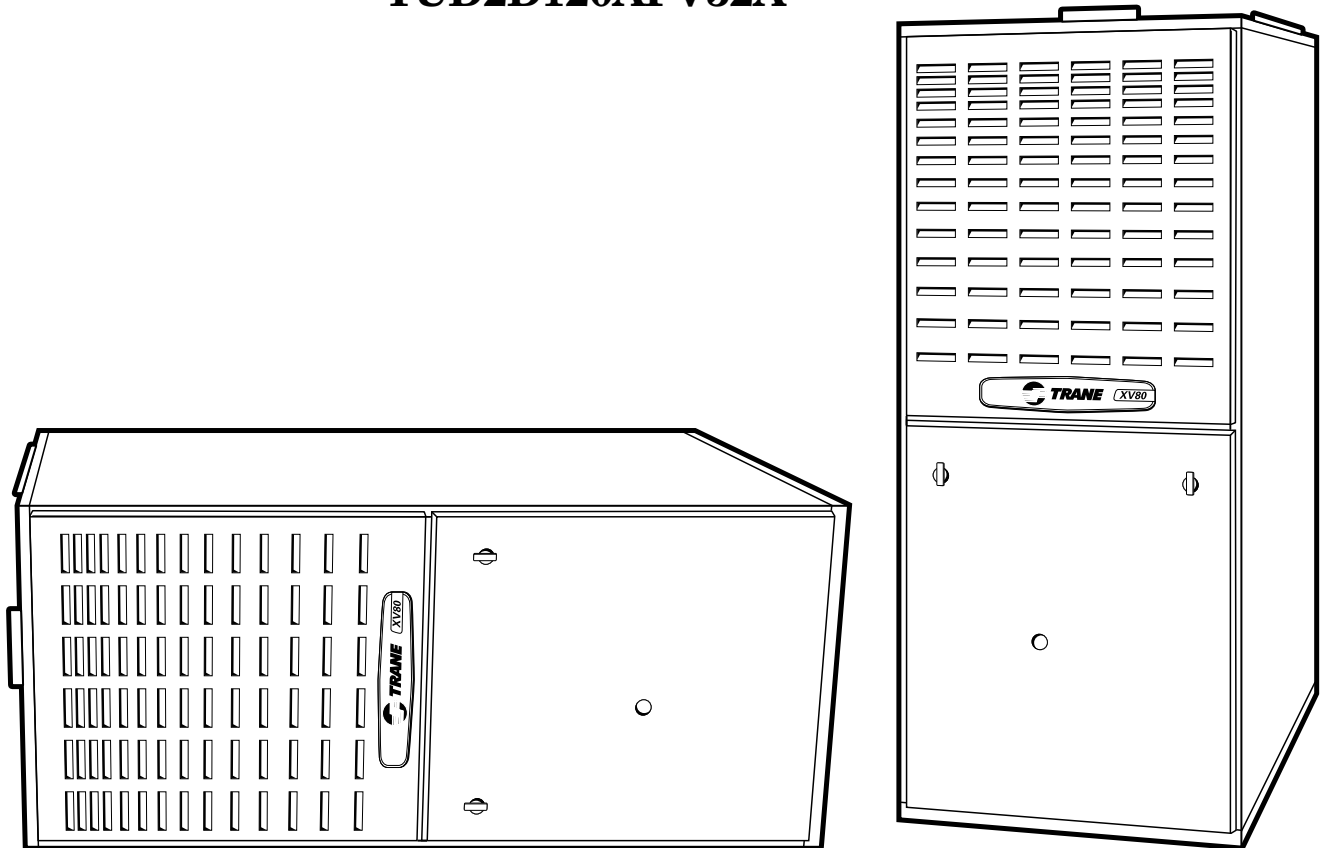

Upflow/Horizontal 80% 2-Stage, Variable Speed Gas-Fired Furnace with Whole House Air Cleaner

XV80i

**TUD2B060AFV32A, TUD2B080AFV32A,
TUD2C080AFV42A, TUD2B100AFV32A,
TUD2D120AFV52A**



PUB. NO. 22-1802-03



Features Summary

WHOLE HOUSE AIR CLEANER

The Whole House Air Cleaner uses advanced technology to remove up to 99.98% of allergens from the filtered air and removes particles down to .3 microns in size. Cleaning intervals of 1-3 months are typical, depending on the home environment.

NATURAL GAS MODELS

Central Heating furnace designs are certified by the American Gas Association for both natural and L.P. gas. Limit setting and rating data were established and approved under standard rating conditions using American National Standards Institute standards.

SAFE OPERATION

The Integrated System Control has solid state devices, which continuously monitor for presence of flame, when the system is in the heating mode of operation. Dual solenoid combination gas valve and regulator provide extra safety.

QUICK HEATING

Durable, cycle tested, heavy gauge aluminized steel heat exchanger quickly transfers heat to provide warm conditioned air to the structure. Low energy power vent blower, to increase efficiency and provide a positive discharge of gas fumes to the outside.

BURNERS

Multiport In-shot burners will give years of quiet and efficient service. All models can be converted to L.P. gas.

INTEGRATED SYSTEM CONTROL

Exclusively designed operational program provides total control of furnace limit sensors, blowers, gas valve, flame control and includes self diagnostics for ease of service. Also contains connection points for humidifier.

AIR DELIVERY

The variable speed, direct drive blower motor, has sufficient airflow for most heating and cooling requirements, will switch from heating to cooling speeds on demand from room thermostat. The blower door safety switch will prevent or terminate furnace operation when the blower door is removed.

STYLING

Heavy gauge steel and "wrap-around" cabinet construction is used in the cabinet with baked-on enamel finish for strength and beauty. The heat exchanger section of the cabinet is completely lined with foil faced fiberglass insulation. This results in quiet and efficient operation due to the excellent acoustical and insulating qualities of fiberglass. Built-in bottom pan and bottom return air connection.

FEATURES AND GENERAL OPERATION

The XV80i High Efficiency Gas Furnaces employ a Hot Surface Ignition system, which eliminates the waste of a constant burning pilot. The integrated system control lights the main burners upon a demand for heat from the room thermostat. Complete front service access.

- a. Low energy power venter
- b. Vent proving pressure switch.

Contents

Feature Summary	2
Features and Benefits	4
Standard Equipment	
Optional Equipment	
General Data	6
TUD2B060AFV32A	
TUD2B080AFV32A	
TUD2C080AFV42A	
TUD2B100AFV42A	
TUD2D120AFV52A	
Performance Data	8
Electric Data	13
Field Wiring Diagrams	15
Dimensions	20



Features and Benefits

XV80i STANDARD EQUIPMENT

- Whole House Air Cleaner
- Upflow/Horizontal
- Power supply 115/1/60
- 2-stage gas valve
- 2-speed venter
- Variable speed ECM blower motor
- Silicon Nitride hot surface igniter with adaptive heat up
- Integrated solid state control
- Attractive color accents
- Heavy gauge aluminized steel heat exchanger
- Multi-port In-shot burners
- Complete front service access
- Alternate bottom/left/right return air
- Slide out blower assembly
- Hinged blower door
- Perfect fit door catches
- Insulated bower door
- Gasketed blower door
- Two tone color
- Integrated solid state control with self-diagnostics
- Common vent capability
- Optional L.P. conversion kit
- Left/right gas connection
- Accessory hook-up capability
- Selectable cooling fan off delay eliminates need for BAY24X045time delay kit
- Enhanced cooling control



Features and Benefits

XV80i OPTIONAL EQUIPMENT

Thermostat, Mechanical 2-Stage Heating/ 1-Stage Cooling	TAYSTAT241 []
Thermostat, Mechanical Heating Only With Fan Switch	BAYSTAT303 []
Thermostat, Mechanical Heating Only	BAYSTAT388 []
Thermostat, Heating/Cooling Single Stage (Mounts Horizontally)	AY28X092 []
Thermostat, Electronic Non-programmable 1-Stage Heating/1-Stage Cooling	BAYSTAT370 []
Thermostat, Electronic Programmable (5-2) 1-Stage Heating/1-Stage Cooling	BAYSTAT340 []
Thermostat, Heating/Cooling Single Stage (Mounts Vertically)	BAYSTAT305 []
Thermostat, Electronic Programmable 2-Stage Heating/2-Stage Cooling	TAYSTAT302C []
Thermostat, Electronic Programmable 1-Stage Heating/1-Stage Cooling	TAYSTAT300C []
Propane Conversion Kit	BAYLPKT210A []
Coil Enclosure (17-1/2" Wide Cabinets)	BAYCLE1700 []
Coil Enclosure (21" Wide Cabinets)	BAYCLE2100 []
Coil Enclosure (24-1/2" Wide Cabinets)	BAYCLE2400 []
High Altitude Switch	BAYHALT249 []
Masonry Chimney Vent Kit	BAYVENT800B []



General Data

Product Specifications ^①

MODEL	*UD2B060AFV32A	*UD2B080AFV32A	*UD2C080AFV42A
TYPE	Upflow / Horizontal	Upflow / Horizontal	Upflow / Horizontal
RATINGS ^②			
1st Stage Input BTUH	39,000	52,000	52,000
1st Stage Capacity BTUH (ICS) ^③	31,200	41,600	41,600
2nd Stage Input BTUH	60,000	80,000	80,000
2nd Stage Capacity BTUH (ICS) ^③	48,000	64,000	64,000
Temp. rise (Min.-Max.) °F.	30 - 60	30 - 60	30 - 60
BLOWER DRIVE			
	Direct	Direct	Direct
Diameter - Width (In.)	10 x 7	10 x 7	10 x 10
No. Used	1	1	1
Speeds (No.)	Variable	Variable	Variable
CFM vs. in. w.g.	See Airflow Table	See Airflow Table	See Airflow Table
Motor HP	1/2	1/2	3/4
R.P.M.	Variable	Variable	Variable
Volts / Ph / Hz	115/1/60	115/1/60	115/1/60
COMBUSTION FAN — Type			
	Centrifugal	Centrifugal	Centrifugal
Drive - No. Speeds	Direct - 2	Direct - 2	Direct - 2
Motor HP - RPM	1/100 - 2543/1727	1/100 - 2543/1727	1/100 - 2543/1727
Volts / Ph / Hz	115/1/60	115/1/60	115/1/60
FLA	0.70/0.40	0.70/0.40	0.70/0.40
FILTER — Furnished?			
	Yes	Yes	Yes
Type	Whole House Air Cleaner	Whole House Air Cleaner	Whole House Air Cleaner
Max. Indoor Relative Humidity ^⑤	65%	65%	65%
VENT — Size (In.)			
	4 Round	4 Round	4 Round
HEAT EXCHANGER			
Type -Fired	Alum. Steel - Type 1	Alum. Steel - Type 1	Alum. Steel - Type 1
-Unfired			
Gauge (Fired)	20	20	20
ORIFICES — Main			
Nat. Gas Qty. — Drill Size	3 — 45	4 — 45	4 — 45
L.P. Gas Qty. — Drill Size	3 — 56	4 — 56	4 — 56
GAS VALVE			
	Redundant - Two Stage	Redundant - Two Stage	Redundant - Two Stage
PILOT SAFETY DEVICE			
Type	Hot Surface Ignition	Hot Surface Ignition	Hot Surface Ignition
BURNERS — Type			
	Multi-port In-shot	Multi-port In-shot	Multi-port In-shot
Number	3	4	4
POWER CONN. — V / Ph / Hz ^④			
	115/1/60	115/1/60	115/1/60
Ampacity (In Amps)	10.5	10.5	12.9
Max. Overcurrent Protection (Amps)	15	15	20
PIPE CONN. SIZE (In.)			
	1/2	1/2	1/2
DIMENSIONS			
	H x W x D	H x W x D	H x W x D
Crated (In.)	41-3/4 x 19-1/2 x 30-1/2	41-3/4 x 19-1/2 x 30-1/2	41-3/4 x 23 x 30-1/2
Uncrated (In.)	40 x 17-1/2 x 28-1/2	40 x 17-1/2 x 28-1/2	40 x 21 x 28-1/2
WEIGHT			
Shipping (Lbs.) / Net (Lbs.)	136 / 126	142 / 132	166 / 155

^① Central Furnace heating designs are certified by AGA and CSA.

^② For U.S. applications, above input ratings (BTUH) are up to 2,000 feet, derate 4% per 1,000 feet for elevations above 2,000 feet above sea level. For Canadian applications, above input ratings (BTUH) are up to 4,500 feet, derate 4% per 1,000 feet for elevations above 4,500 feet above sea level.

^③ Based on U.S. government standard tests.

^④ The above wiring specifications are in accordance with National Electrical Code; however, installations must comply with local codes.

^⑤ The FIELD CHARGER may require more frequent cleaning in homes with high indoor relative humidity (greater than 65% RH). Consult your service professional about cleaning intervals.



General Data

Product Specifications ^①

MODEL	*UD2B100AFV32A	*UD2D120AFV52A
TYPE	Upflow / Horizontal	Upflow / Horizontal
RATINGS ^②		
1st Stage Input BTUH	65,000	78,000
1st Stage Capacity BTUH (ICS) ^③	52,000	62,400
2nd Stage Input BTUH	100,000	120,000
2nd Stage Capacity BTUH (ICS) ^③	80,000	97,000
Temp. rise (Min.-Max.) °F.	40 - 70	35 - 65
BLOWER DRIVE	Direct	Direct
Diameter - Width (In.)	10 x 7	10 x 10
No. Used	1	1
Speeds (No.)	Variable	Variable
CFM vs. in. w.g.	See Airflow Table	See Airflow Table
Motor HP	1/2	1
R.P.M.	Variable	Variable
Volts / Ph / Hz	115/1/60	115/1/60
COMBUSTION FAN — Type	Centrifugal	Centrifugal
Drive - No. Speeds	Direct - 2	Direct - 2
Motor HP - RPM	1/75 - 2708/1868	1/60 - 3090/2225
Volts / Ph / Hz	115/1/60	115/1/60
FLA	0.87/0.49	1.14/0.51
FILTER — Furnished?	Yes	Yes
Type	Whole House Air Cleaner	Whole House Air Cleaner
Max. Indoor Relative Humidity ^⑤	65%	65%
VENT — Size (In.)	4 Round	4 Round
HEAT EXCHANGER		
Type -Fired	Alum. Steel - Type 1	Alum. Steel - Type 1
-Unfired		
Gauge (Fired)	20	20
ORIFICES — Main		
Nat. Gas. Qty. — Drill Size	5 — 45	6 — 45
L.P. Gas Qty. — Drill Size	5 — 56	6 — 56
GAS VALVE	Redundant - Two Stage	Redundant - Two Stage
PILOT SAFETY DEVICE		
Type	Hot Surface Ignition	Hot Surface Ignition
BURNERS — Type	Multi-port In-shot	Multi-port In-shot
Number	5	6
POWER CONN. — V / Ph / Hz ^④	115/1/60	115/1/60
Ampacity (In Amps)	10.8	15.3
Max. Overcurrent Protection (Amps)	15	20
PIPE CONN. SIZE (In.)	1/2	1/2
DIMENSIONS	H x W x D	H x W x D
Crated (In.)	41-3/4 x 19-1/2 x 30-1/2	41-3/4 x 26-1/2 x 30-1/2
Uncrated (In.)	40 x 17-1/2 x 28-1/2	40 x 24-1/2 x 28-1/2
WEIGHT		
Shipping (Lbs.) / Net (Lbs.)	142 / 132	193 / 181

① Central Furnace heating designs are certified by AGA and CSA.

② For U.S. applications, above input ratings (BTUH) are up to 2,000 feet, derate 4% per 1,000 feet for elevations above 2,000 feet above sea level. For Canadian applications, above input ratings (BTUH) are up to 4,500 feet, derate 4% per 1,000 feet for elevations above 4,500 feet above sea level.

③ Based on U.S. government standard tests.

④ The above wiring specifications are in accordance with National Electrical Code; however, installations must comply with local codes.

⑤ The FIELD CHARGER may require more frequent cleaning in homes with high indoor relative humidity (greater than 65% RH). Consult your service professional about cleaning intervals.



Performance Data

*UD2B060AFV32A Furnace Heating Airflow (CFM) and Power (watts) vs. External Static Pressure With Filter										
	Airflow Setting	Dip Switch Setting			External Static Pressure					
		SW7	SW8		0.1	0.3	0.5	0.7	0.9	
Heating	Heating 1st Stage	Low	ON	ON	CFM	583	590	625	622	620
					Temp. Rise	50	49	46	46	47
					Watts	60	87	126	157	192
		Medium**	ON	OFF	CFM	635	687	701	695	694
					Temp. Rise	45	42	41	42	42
					Watts	69	110	148	183	221
	High	OFF	OFF	CFM	746	778	803	819	823	
				Temp. Rise	39	37	36	35	35	
				Watts	97	140	185	230	272	
	Heating 2nd Stage	Low	ON	ON	CFM	779	816	848	866	874
					Temp. Rise	57	54	52	51	51
					Watts	104	152	201	255	302
Medium**		ON	OFF	CFM	872	939	964	976	985	
				Temp. Rise	51	47	46	46	45	
				Watts	136	203	264	312	365	
High		OFF	OFF	CFM	1069	1102	1102	1110	1078	
				Temp. Rise	42	40	40	40	41	
				Watts	227	293	345	403	429	

*UD2B060AFV32A Furnace Cooling Airflow (CFM) and Power (Watts) vs. External Static Pressure With Filter												
Unit Outdoor	Airflow Setting	Dip Switch Setting					External Static Pressure					
		SW1	SW2	SW3	SW4		0.1	0.3	0.5	0.7	0.9	
Cooling	1.5	Low (350 CFM/Ton)	ON	ON	OFF	ON	CFM	517	535	538	546	542
							Watts	49	76	105	141	171
		Normal (400 CFM/ton)	ON	ON	OFF	OFF	CFM	587	594	629	622	618
							Watts	61	89	129	159	196
		High (450 CFM/ton)	ON	ON	ON	OFF	CFM	642	677	705	701	696
							Watts	73	109	151	185	222
	2	Low (350 CFM/Ton)	OFF	ON	OFF	ON	CFM	676	705	729	736	738
							Watts	79	118	159	198	240
		Normal (400 CFM/ton)	OFF	ON	OFF	OFF	CFM	776	814	833	863	867
							Watts	103	150	200	251	298
		High (450 CFM/ton)	OFF	ON	ON	OFF	CFM	870	928	961	974	975
							Watts	137	198	259	316	361
2.5	Low (350 CFM/Ton)	ON	OFF	OFF	ON	CFM	831	883	915	935	941	
						Watts	122	182	238	292	345	
	Normal (400 CFM/ton)	ON	OFF	OFF	OFF	CFM	1023	1052	1055	1061	1048	
						Watts	203	266	316	370	413	
	High (450 CFM/ton)	ON	OFF	ON	OFF	CFM	1156	1174	1188	1196	1085	
						Watts	280	351	415	482	442	
3**	Low (350 CFM/Ton)	OFF	OFF	OFF	ON	CFM	1063	1094	1090	1100	1070	
						Watts	226	290	344	397	430	
	Normal** (400)	OFF	OFF	OFF	OFF	CFM	1214	1241	1263	1234	1123	
						Watts	320	395	476	514	469	
	High (450 CFM/ton)	OFF	OFF	ON	OFF	CFM	1399	1409	1377	1278	1164	
						Watts	486	575	604	559	507	

Notes:

- * First letter may be "A" or "T".
- ** Factory setting.
- Continuous Fan Setting: Heating or cooling airflow is approximately 50% of selected cooling value.
- For variable speed low speed airflows are approximately 30% of listed values.
- LOW 350 cfm/ton is recommended for variable speed application for COMFORT & HUMID CLIMATE setting; NORMAL is 400 cfm/ton; HIGH 450 cfm/ton is for DRY CLIMATE setting.



Performance Data

*UD2B080AFV32A Furnace Heating Airflow (CFM) and Power (watts) vs. External Static Pressure With Filter									
	Airflow Setting	Dip Switch Setting			External Static Pressure				
		SW7	SW8		0.1	0.3	0.5	0.7	0.9
Heating 1st Stage	Low	ON	ON	CFM	846	852	836	811	810
				Temp. Rise	46	45	46	48	48
				Watts	127	167	200	229	270
	Medium**	ON	OFF	CFM	969	956	936	915	897
				Temp. Rise	40	40	41	42	43
				Watts	182	218	251	283	317
	High	OFF	OFF	CFM	1126	1116	1108	1095	1074
				Temp. Rise	34	35	35	35	36
				Watts	270	316	361	404	441
Heating 2nd Stage	Low	ON	ON	CFM	1216	1205	1189	1169	1111
				Temp. Rise	49	49	50	51	53
				Watts	333	383	429	468	473
	Medium**	ON	OFF	CFM	1362	1347	1324	1254	1145
				Temp. Rise	44	44	45	47	52
				Watts	468	518	559	550	500
	High	OFF	OFF	CFM	1474	1419	1370	1258	1148
				Temp. Rise	40	42	43	47	52
				Watts	590	601	609	558	506

*UD2B080AFV32A Furnace Cooling Airflow (CFM) and Power (Watts) vs. External Static Pressure With Filter											
Unit Outdoor	Airflow Setting	Dip Switch Setting					External Static Pressure				
		SW1	SW2	SW3	SW4		0.1	0.3	0.5	0.7	0.9
2.5	Low (350 CFM/Ton)	OFF	ON	OFF	ON	CFM	934	926	913	889	863
						Watts	162	201	236	267	296
	Normal (400 CFM/ton)	OFF	ON	OFF	OFF	CFM	1063	1051	1042	1029	1008
						Watts	228	272	315	356	394
	High (450 CFM/ton)	OFF	ON	ON	OFF	CFM	1220	1212	1199	1179	1119
						Watts	334	386	433	471	475
3	Low (350 CFM/Ton)	ON	OFF	OFF	ON	CFM	1131	1122	1111	1101	1083
						Watts	269	317	361	405	442
	Normal (400 CFM/ton)	ON	OFF	OFF	OFF	CFM	1310	1295	1273	1246	1136
						Watts	405	457	498	535	490
	High (450 CFM/ton)	ON	OFF	ON	OFF	CFM	1458	1420	1369	1266	1154
						Watts	569	599	606	561	506
3.5**	Low (350 CFM/Ton)	OFF	OFF	OFF	ON	CFM	1329	1310	1287	1253	1142
						Watts	424	472	516	542	493
	Normal (400 CFM/ton)	OFF	OFF	OFF	OFF	CFM	1475	1422	1369	1272	1158
						Watts	585	596	605	563	510
	High (450 CFM/ton)	OFF	OFF	ON	OFF	CFM	1473	1421	1367	1269	1152
						Watts	585	595	605	558	505

Notes:

- * First letter may be "A" or "T".
- ** Factory setting.
- Continuous Fan Setting: Heating or cooling airflow is approximately 50% of selected cooling value.
- For variable speed low speed airflows are approximately 30% of listed values.
- LOW 350 cfm/ton is recommended for variable speed application for COMFORT & HUMID CLIMATE setting; NORMAL is 400 cfm/ton; HIGH 450 cfm/ton is for DRY CLIMATE setting.



Performance Data

*UD2C080AFV42A Furnace Heating Airflow (CFM) and Power (watts) vs. External Static Pressure With Filter										
	Airflow Setting	Dip Switch Setting			External Static Pressure					
		SW7	SW8		0.1	0.3	0.5	0.7	0.9	
Heating	Heating 1st Stage	Low	ON	ON	CFM	745	758	758	761	735
					Temp. Rise	52	51	51	51	52
					Watts	68	111	153	197	231
		Medium**	ON	OFF	CFM	839	864	851	851	822
					Temp. Rise	46	45	45	45	47
					Watts	87	134	181	224	263
	High	OFF	OFF	CFM	934	961	943	941	933	
				Temp. Rise	41	40	41	41	41	
				Watts	110	164	211	263	310	
	Heating 2nd Stage	Low	ON	ON	CFM	1064	1077	1085	1086	1077
					Temp. Rise	56	55	55	55	55
					Watts	152	205	262	325	379
Medium**		ON	OFF	CFM	1197	1226	1241	1230	1229	
				Temp. Rise	50	48	48	48	48	
				Watts	201	271	338	395	462	
High	OFF	OFF	CFM	1345	1375	1376	1371	1320		
			Temp. Rise	44	43	43	43	45		
			Watts	272	348	418	480	517		

*UD2C080AFV42A Furnace Cooling Airflow (CFM) and Power (Watts) vs. External Static Pressure With Filter												
Unit Outdoor	Airflow Setting	Dip Switch Setting					External Static Pressure					
		SW1	SW2	SW3	SW4		0.1	0.3	0.5	0.7	0.9	
Cooling	2.5	Low (350 CFM/Ton)	ON	ON	OFF	ON	CFM	840	862	850	846	824
							Watts	87	135	182	223	264
		Normal (400 CFM/ton)	ON	ON	OFF	OFF	CFM	962	977	974	973	965
							Watts	118	167	221	276	320
		High (450 CFM/ton)	ON	ON	ON	OFF	CFM	1076	1095	1104	1102	1096
							Watts	153	212	271	331	390
	3	Low (350 CFM/Ton)	OFF	ON	OFF	ON	CFM	1004	1018	1016	1019	1007
							Watts	130	183	236	297	343
		Normal (400 CFM/ton)	OFF	ON	OFF	OFF	CFM	1143	1176	1187	1184	1180
							Watts	180	267	311	368	436
		High (450 CFM/ton)	OFF	ON	ON	OFF	CFM	1303	1334	1337	1334	1296
							Watts	252	326	394	456	502
3.5	Low (350 CFM/Ton)	ON	OFF	OFF	ON	CFM	1167	1193	1208	1196	1193	
						Watts	190	255	321	378	443	
	Normal (400 CFM/ton)	ON	OFF	OFF	OFF	CFM	1356	1378	1383	1358	1321	
						Watts	279	355	424	473	518	
	High (450 CFM/ton)	ON	OFF	ON	OFF	CFM	1521	1528	1537	1537	1344	
						Watts	379	545	534	606	556	
4**	Low (350 CFM/Ton)	OFF	OFF	OFF	ON	CFM	1351	1376	1377	1364	1312	
						Watts	275	357	422	467	515	
	Normal** (400)	OFF	OFF	OFF	OFF	CFM	1537	1548	1561	1534	1347	
						Watts	392	468	552	606	538	
	High (450 CFM/ton)	OFF	OFF	ON	OFF	CFM	1738	1755	1735	1568	1382	
						Watts	543	652	708	635	563	

Notes:

- * First letter may be "A" or "T".
- ** Factory setting.
- Continuous Fan Setting: Heating or cooling airflow is approximately 50% of selected cooling value.
- For variable speed low speed airflows are approximately 30% of listed values.
- LOW 350 cfm/ton is recommended for variable speed application for COMFORT & HUMID CLIMATE setting; NORMAL is 400 cfm/ton; HIGH 450 cfm/ton is for DRY CLIMATE setting.



Performance Data

*UD2B100AFV32A Furnace Heating Airflow (CFM) and Power (watts) vs. External Static Pressure With Filter										
Heating	Airflow Setting	Dip Switch Setting			External Static Pressure					
		SW7	SW8		0.1	0.3	0.5	0.7	0.9	
	Heating 1st Stage	Low	ON	ON	CFM	764	795	832	852	848
Temp. Rise					63	61	58	56	57	
Watts					103	147	195	242	280	
Medium**		ON	OFF	CFM	875	938	963	974	959	
				Temp. Rise	55	60	58	57	58	
				Watts	139	200	259	305	344	
High		OFF	OFF	CFM	984	1029	1040	1039	980	
				Temp. Rise	49	47	46	46	49	
				Watts	185	253	304	347	357	
Heating 2nd Stage	Low	ON	ON	CFM	1118	1138	1157	1125	1018	
				Temp. Rise	66	65	64	66	73	
				Watts	262	326	390	417	383	
	Medium**	ON	OFF	CFM	1310	1335	1277	1192	1097	
				Temp. Rise	57	55	58	62	68	
				Watts	411	498	498	472	441	
	High	OFF	OFF	CFM	1413	1399	1322	1233	1148	
				Temp. Rise	52	53	56	60	65	
				Watts	512	566	541	514	484	

*UD2B100AFV32A Furnace Cooling Airflow (CFM) and Power (Watts) vs. External Static Pressure With Filter											
Unit Outdoor	Airflow Setting	Dip Switch Setting					External Static Pressure				
		SW1	SW2	SW3	SW4		0.1	0.3	0.5	0.7	0.9
1.5	Low (350 CFM/Ton)	ON	ON	OFF	ON	CFM	538	556	574	579	570
						Watts	54	80	113	145	176
	Normal (400 CFM/ton)	ON	ON	OFF	OFF	CFM	598	626	654	647	647
						Watts	64	94	131	162	200
	High (450 CFM/ton)	ON	ON	ON	OFF	CFM	657	706	713	724	730
						Watts	75	116	151	187	227
2	Low (350 CFM/Ton)	OFF	ON	OFF	ON	CFM	688	729	745	753	763
						Watts	81	124	161	199	238
	Normal (400 CFM/ton)	OFF	ON	OFF	OFF	CFM	785	831	859	872	881
						Watts	109	157	207	253	294
	High (450 CFM/ton)	OFF	ON	ON	OFF	CFM	887	939	964	977	954
						Watts	146	206	260	309	343
2.5	Low (350 CFM/Ton)	ON	OFF	OFF	ON	CFM	848	907	934	946	946
						Watts	133	188	245	289	334
	Normal (400 CFM/ton)	ON	OFF	OFF	OFF	CFM	1018	1044	1055	1065	983
						Watts	206	262	319	370	357
	High (450 CFM/ton)	ON	OFF	ON	OFF	CFM	1139	1160	1184	1122	1020
						Watts	274	344	411	417	386
3.0**	Low (350 CFM/Ton)	OFF	OFF	OFF	ON	CFM	1071	1089	1105	1108	1003
						Watts	231	290	346	399	368
	Normal (400 CFM/ton)	OFF	OFF	OFF	OFF	CFM	1208	1246	1249	1153	1060
						Watts	323	411	469	441	410
	High (450 CFM/ton)	OFF	OFF	ON	OFF	CFM	1387	1383	1295	1221	1124
						Watts	482	546	517	499	467

Notes:

- * First letter may be "A" or "T".
- ** Factory setting.
- Continuous Fan Setting: Heating or cooling airflow is approximately 50% of selected cooling value.
- For variable speed low speed airflows are approximately 30% of listed values.
- LOW 350 cfm/ton is recommended for variable speed application for COMFORT & HUMID CLIMATE setting; NORMAL is 400 cfm/ton; HIGH 450 cfm/ton is for DRY CLIMATE setting.



Performance Data

*UD2D120AFV52A Furnace Heating Airflow (CFM) and Power (watts) vs. External Static Pressure With Filter										
	Airflow Setting	Dip Switch Setting			External Static Pressure					
		SW7	SW8		0.1	0.3	0.5	0.7	0.9	
Heating	Heating 1st Stage	Low	ON	ON	CFM	1003	1039	1062	1033	1034
					Temp. Rise	58	56	54	56	56
					Watts	125	182	246	309	356
		Medium**	ON	OFF	CFM	1137	1193	1185	1197	1185
					Temp. Rise	51	48	49	48	49
					Watts	170	239	293	370	446
	High	OFF	OFF	CFM	1262	1290	1327	1344	1331	
				Temp. Rise	46	45	44	43	43	
				Watts	218	286	366	440	534	
	Heating 2nd Stage	Low	ON	ON	CFM	1415	1454	1476	1500	1421
					Temp. Rise	63	61	60	59	63
					Watts	297	378	453	534	561
Medium**		ON	OFF	CFM	1645	1672	1701	1659	1456	
				Temp. Rise	54	53	52	54	61	
				Watts	435	539	632	671	580	
High	OFF	OFF	CFM	1834	1857	1837	1686	1506		
			Temp. Rise	48	48	48	53	59		
			Watts	608	705	778	699	630		

*UD2D120AFV52A Furnace Cooling Airflow (CFM) and Power (Watts) vs. External Static Pressure With Filter												
Unit Outdoor	Airflow Setting	Dip Switch Setting					External Static Pressure					
		SW1	SW2	SW3	SW4		0.1	0.3	0.5	0.7	0.9	
Cooling	3.5	Low (350 CFM/Ton)	OFF	ON	OFF	ON	CFM	1141	1197	1205	1196	1188
							Watts	170	246	299	369	443
		Normal (400 CFM/ton)	OFF	ON	OFF	OFF	CFM	1325	1374	1403	1434	1412
							Watts	252	332	408	496	567
		High (450 CFM/ton)	OFF	ON	ON	OFF	CFM	1536	1575	1615	1619	1474
							Watts	370	464	563	640	605
	4	Low (350 CFM/Ton)	ON	OFF	OFF	ON	CFM	1334	1376	1424	1411	1417
							Watts	251	330	415	469	562
		Normal (400 CFM/ton)	ON	OFF	OFF	OFF	CFM	1582	1628	1659	1663	1465
Watts							387	491	595	672	595	
High (450 CFM/ton)		ON	OFF	ON	OFF	CFM	1813	1836	1838	1707	1504	
						Watts	577	684	771	710	620	
5**	Low (350 CFM/Ton)	OFF	OFF	OFF	ON	CFM	1704	1731	1733	1735	1552	
						Watts	489	589	666	750	663	
	Normal (400 CFM/ton)	OFF	OFF	OFF	OFF	CFM	1960	1971	1937	1799	1602	
						Watts	739	841	891	813	700	
	High (450 CFM/ton)	OFF	OFF	ON	OFF	CFM	2208	2107	1970	1849	1683	
						Watts	1080	1025	942	863	776	

Notes:

- * First letter may be "A" or "T".
- ** Factory setting.
- Continuous Fan Setting: Heating or cooling airflow is approximately 50% of selected cooling value.
- For variable speed low speed airflows are approximately 30% of listed values.
- LOW 350 cfm/ton is recommended for variable speed application for COMFORT & HUMID CLIMATE setting; NORMAL is 400 cfm/ton; HIGH 450 cfm/ton is for DRY CLIMATE setting.

Electrical Data

SCHEMATIC DIAGRAMS FOR GAS FURNACES

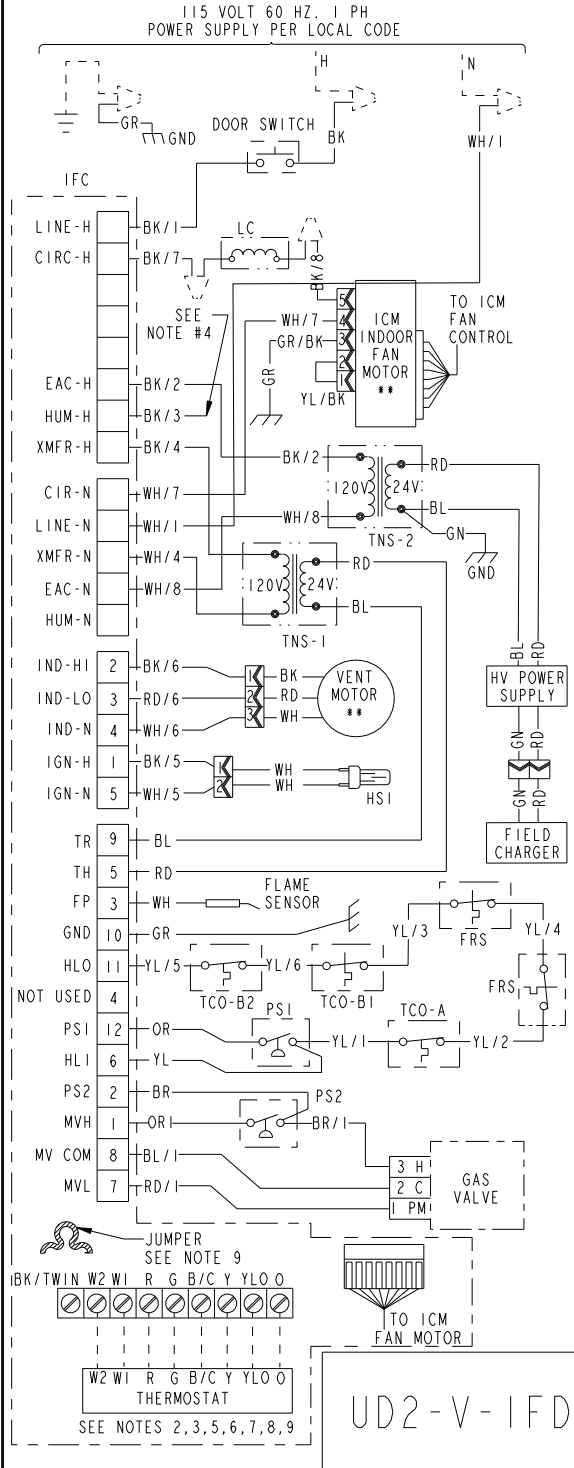

TABLE "A"	
MODELS	
*UD2B060AFV3V32**	
*UD2B080AFV3V32**	
*UD2C080AFV4V42**	
*UD2C100AFV4V32**	
*UD2D120AFV5V52**	
* PREFIX MAY BE "A" OR "T"	
** SUFFIX MAY BE "AA"-"ZZ"	

WARNING	
HAZARDOUS VOLTAGE: DISCONNECT ALL ELECTRICAL POWER INCLUDING REMOTE DISCONNECTS BEFORE SERVICING. FAILURE TO DISCONNECT POWER BEFORE SERVICING CAN CAUSE SEVERE PERSONAL INJURY OR DEATH.	
CAUTION	
USE COPPER CONDUCTORS ONLY! UNIT TERMINALS ARE NOT DESIGNED TO ACCEPT OTHER TYPES OF CONDUCTORS. FAILURE TO DO SO MAY CAUSE DAMAGE TO THE EQUIPMENT.	

DIAGNOSTIC CODES	
FLASHING SLOW: NORMAL - NO CALL FOR HEAT	
FLASHING FAST: NORMAL - CALL FOR HEAT	
CONTINUOUS ON: REPLACE IFC	
CONTINUOUS OFF: CHECK POWER	
2 FLASHES: EXTERNAL LOCKOUT (RETRIES OR RECYCLES EXCEEDED)	
3 FLASHES: PRESSURE SWITCH ERROR	
4 FLASHES: OPEN LIMIT DEVICE	
5 FLASHES: FLAME SENSED WHEN NO FLAME SHOULD BE PRESENT	
6 FLASHES: 115 VAC POWER REVERSED POLARITY OR POOR GROUNDING	
7 FLASHES: GAS VALVE CIRCUIT ERROR	
8 FLASHES: LOW FLAME SENSE SIGNAL	
9 FLASHES: CHECK IGNITER	

INTEGRATED FURNACE CONTROL	
REPLACE WITH PART CNT03078 OR EQUIVALENT	
ELECTRICAL RATING	
INPUT: 25 VAC, 60 HZ.	
XFMR SEC. CURRENT: 450 MA.	
MV 1ST STAGE OUTPUT: 1.5 A @ 24 VAC	
MV 2ND STAGE OUTPUT: 0.5 A @ 24 VAC	
IND OUTPUT: 2.2 FLA, 3.5 LRA @ 120 VAC	
CIRC. BLOWER OUTPUT: 14.5 FLA, 25 LRA @ 120 VAC	
HUMIDIFIER	
MAX. LOAD: 1.0 A @ 120 VAC	
IGNITER OUTPUT: 2.0 A @ 120 VAC	
TIMINGS	
IGN WARMUP: 20 SEC.	
RETRIES: 2 RECYCLES: 10	
HEAT ON DELAY: 45 SEC.	
COOL ON DELAY: 2 SEC.	

	TCO THERMAL CUT OUT		LINE } FACTORY WIRING	BK BLACK	GR GREEN
	PS PRESSURE SWITCH		24 v } WIRING	WH WHITE	BR BROWN
	FRS FLAME ROLLOUT SWITCH		LINE } FIELD WIRING	YL YELLOW	RD RED
	FP FLAME SENSOR		24 v } WIRING	OR ORANGE	BL BLUE
	CHASSIS GROUND			BK/1 WIRE COLOR NUMBER ID (IF ANY)	
	HSI HOT SURFACE IGNITER				
	DOOR SWITCH				
	** INTERNAL THERMAL PROTECTION				
	CF CAPACITOR				
	COIL				
		L LINE	TH 24 VAC (HOT)		
		N NEUTRAL	TR 24 VAC (COMMON)		
		GND GROUND	MV MAIN GAS VALVE		
		B/C COMMON	TNS TRANSFORMER		
		HLO HIGH LIMIT OUTPUT			
		HLI HIGH LIMIT INPUT			

- NOTES:**
- IF ANY OF THE ORIGINAL WIRING AS SUPPLIED WITH THIS FURNACE MUST BE REPLACED, IT MUST BE WITH WIRE HAVING A TEMPERATURE RATING OF AT LEAST 105 C.
 - THERMOSTAT HEAT ANTICIPATOR SETTING: FIRST STAGE .38 AMPS, SECOND STAGE .13 AMPS. IF SETTING IS NOT FIXED ON THERMOSTAT, FOR SINGLE STAGE HEATING THERMOSTAT SET AT .51 AMPS.
 - FOR PROPER OPERATION OF COOLING SPEED, "Y" TERMINAL MUST BE CONNECTED TO THE ROOM THERMOSTAT.
 - THESE LEADS PROVIDE 120V POWER CONNECTIONS HUMIDIFIER (HUM). MAX. LOAD: 1.0 AMPS EACH.
 - JUMPER W1 AND W2 FOR SINGLE STAGE HEATING THERMOSTAT, SECOND STAGE WILL BE ENERGIZED 10 MINUTES AFTER A CALL FOR HEAT.
 - GREEN LIGHT (CFM) FLASHES ONCE PER 100 CFM COMMAND.
 - FOR HEAT PUMP SYSTEMS Y AND O MUST BE CONNECTED TO THE LOW-VOLTAGE TERMINAL BOARD.
 - FOR TWO SPEED SYSTEMS, USE YLO FOR LOW SPEED AND Y FOR HIGH SPEED CONNECTION TO THE LOW-VOLTAGE TERMINAL BOARD.
 - OPTIONAL HUMIDSTAT IS TO BE CONNECTED BETWEEN THE "R" AND "BK". FACTORY INSTALLED JUMPER "R" TO "BK" (W14) ON THE CIRCUIT BOARD MUST BE CUT IF OPTIONAL HUMIDSTAT IS USED. THE JUMPER MUST ALSO BE CUT WHEN APPLYING AN AIRFLOW COMMAND SIGNAL TO THE "BK" INPUT SUCH AS WITH THE VARIABLE SPEED SINGLE-ZONE AND MULTI-ZONE SYSTEM CONTROLLERS. ON SINGLE SPEED COOLING ONLY / NON-HEAT PUMP SYSTEMS, JUMPER "Y" TO "O" FOR PROPER OPERATION OF THE DELAY PROFILES AND THE HUMIDSTAT. FOR TWO COMPRESSOR OR TWO SPEED SYSTEMS, JUMPER "YLO" TO "O".
 - SEE INDOOR MOTOR AIRFLOW SELECTION CHART, LOCATED IN THE FURNACE FOR DIP SWITCH SETTINGS TO SET AIRFLOW AND COOLING OFF DELAYS.
 - POWER MUST BE OFF WHEN DIP SWITCHES ARE SET.
 - USED ON ALL UPFLOW VARIABLE SPEED MODELS EXCEPT FOR *UX2B060AFV3* AND *UX2B080AFV3*.



Field Wiring

FIELD WIRING DIAGRAM FOR VARIABLE SPEED 2 STAGE FURNACE 1 STAGE HEATING USING A 1 STAGE HEATING THERMOSTAT NO COOLING

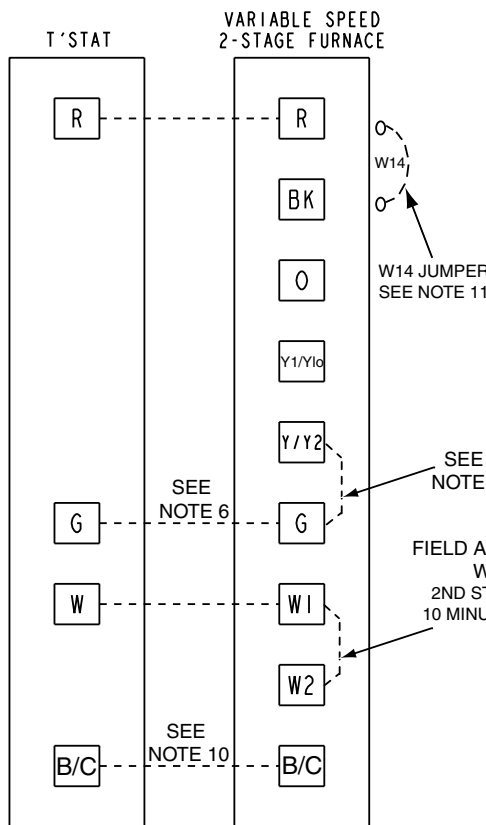

1. Be sure power agrees with equipment nameplates.
2. Low voltage (24 volt wiring) to be No. 18 A.W.G. min.
3. Grounding of equipment must comply with local codes.
4. Set thermostat heat anticipator per unit wiring diagram.
5. These leads provide 115V. power for connection of humidifier MAX. load 1.0 amp.
6. When a single stage heating thermostat without fan switch is used, no wiring on "G" terminal is used.
7. W1 and W2 must be jumpered together for proper operation. Second stage heat will begin 10 minutes after first stage.
8. Set dip switches with power off per installation instructions to set airflow and indoor fan off delays.
9. Continuous fan airflow can be increased by adding this jumper.
10. This wire is only for thermostats requiring connection to transformer common terminal.
11. Optional humidistat is to be connected between R and BK. Factory installed jumper R to BK on the circuit board must be cut if optional humidistat is used. The jumper must also be cut when applying an airflow command signal to the BK input such as with the variable speed single-zone and multi-zone system controllers. On single speed cooling only/non-heat pump systems, jumper Y to O for proper operation of the delay profiles and the humidistat. For two compressor or two speed systems, jumper YLo to O.

FIELD ADDED JUMPER
W1 TO W2.
2ND STAGE WILL FIRE
10 MINUTES AFTER 1ST.

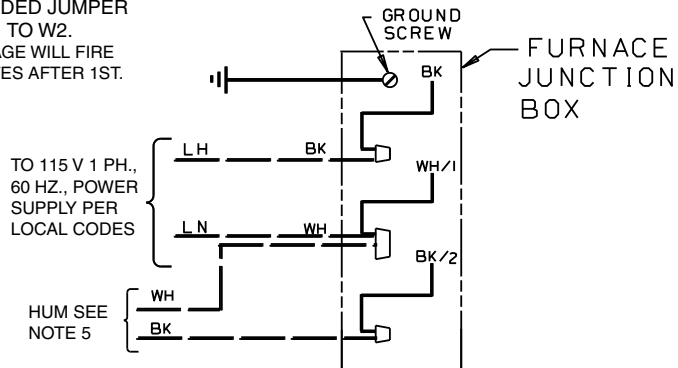

INTER-COMPONENT WIRING

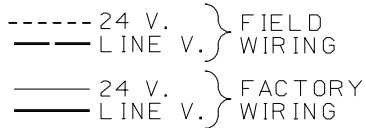

From Dwg. B342027 Rev. 0



Field Wiring

FIELD WIRING DIAGRAM FOR VARIABLE SPEED 2 STAGE FURNACE 2 STAGE HEATING USING A 2 STAGE HEATING THERMOSTAT NO COOLING

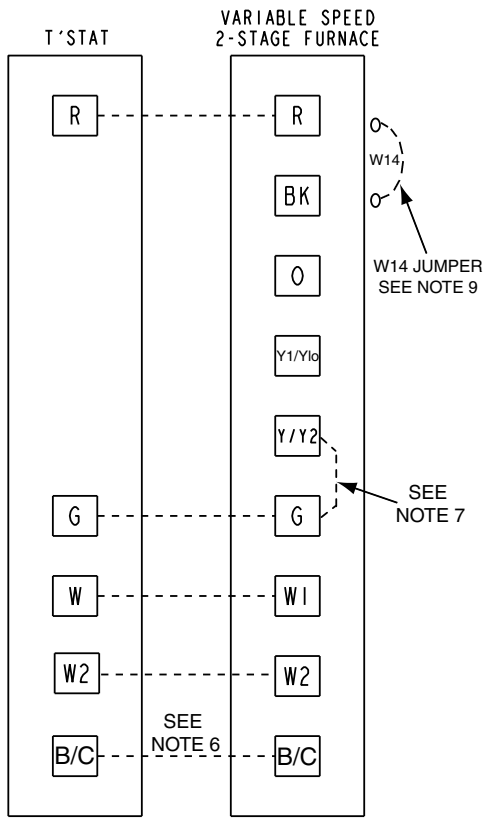

1. Be sure power agrees with equipment nameplates.
2. Low voltage (24 volt wiring) to be No. 18 A.W.G. min.
3. Grounding of equipment must comply with local codes.
4. Set thermostat heat anticipator per unit wiring diagram.
5. These leads provide 115V. power for connection of humidifier MAX. load 1.0 amp.
6. This wire is only for thermostats requiring connection to transformer common terminal.
7. Continuous fan airflow can be increased by adding this jumper.
8. Set dip switches with power off per installation instructions to set airflow and indoor fan off delays.
9. Optional humidistat is to be connected between R and BK. Factory installed jumper R to BK on the circuit board must be cut if optional humidistat is used. The jumper must also be cut when applying an airflow command signal to the BK input such as with the variable speed single-zone and multi-zone system controllers. On single speed cooling only/non-heat pump systems, jumper Y to O for proper operation of the delay profiles and the humidistat. For two compressor or two speed systems, jumper YLo to O.

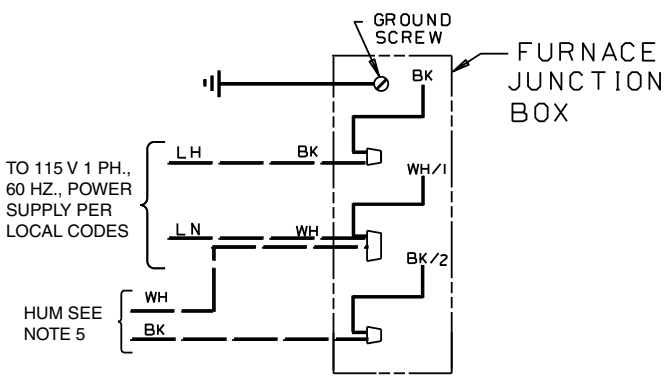

INTER-COMPONENT WIRING

- - - - - 24 V. } FIELD WIRING
 ———— LINE V. }
 - - - - - 24 V. } FACTORY WIRING
 ———— LINE V. }

From Dwg. B342025 Rev. 0

Field Wiring

FIELD WIRING DIAGRAM FOR VARIABLE SPEED 2 STAGE FURNACE 1 STAGE HEATING, 1 STAGE COOLING USING A 1 STAGE HEATING, 1 STAGE COOLING THERMOSTAT (OUTDOOR SECTION WITHOUT TRANSFORMER)

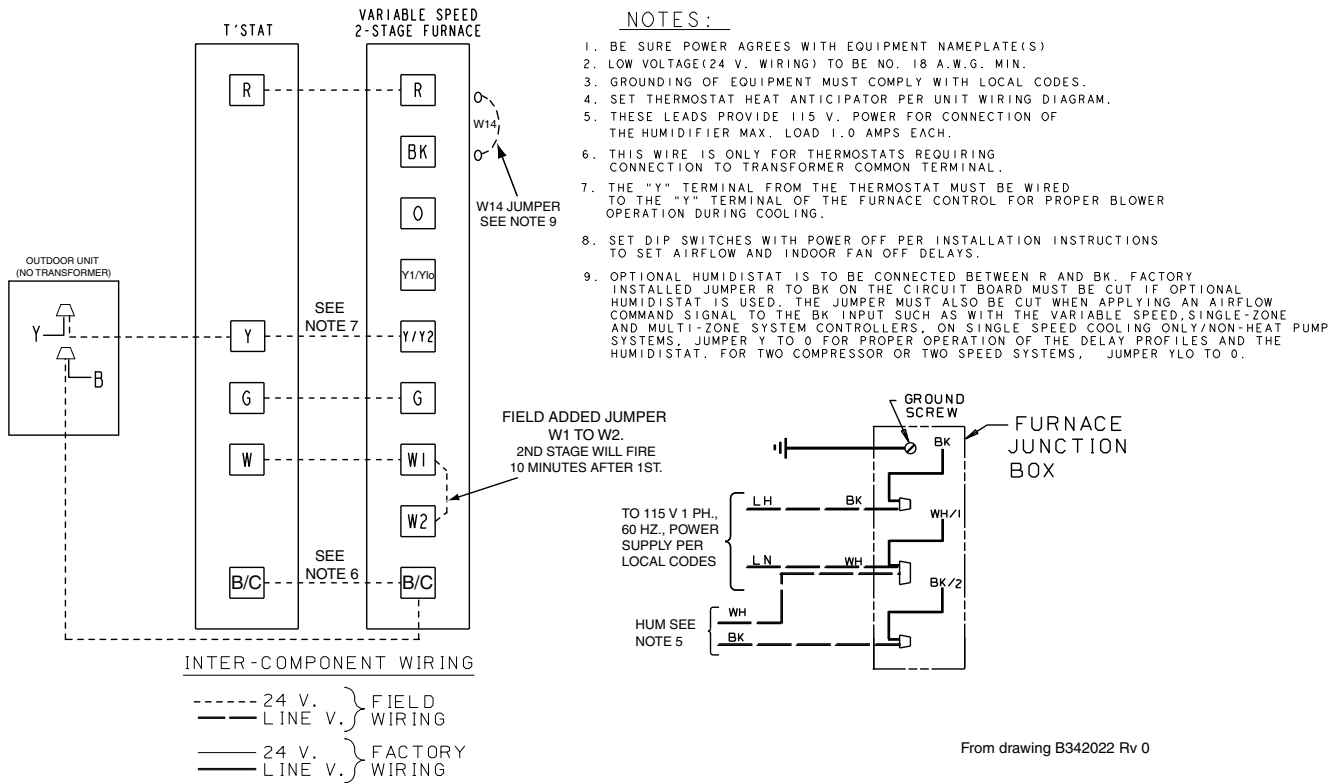

Field Wiring

FIELD WIRING DIAGRAM FOR VARIABLE SPEED 2 STAGE FURNACE 2 STAGE HEATING, 1 STAGE COOLING USING A 2 STAGE HEATING, 1 STAGE COOLING THERMOSTAT (OUTDOOR SECTION WITHOUT TRANSFORMER)

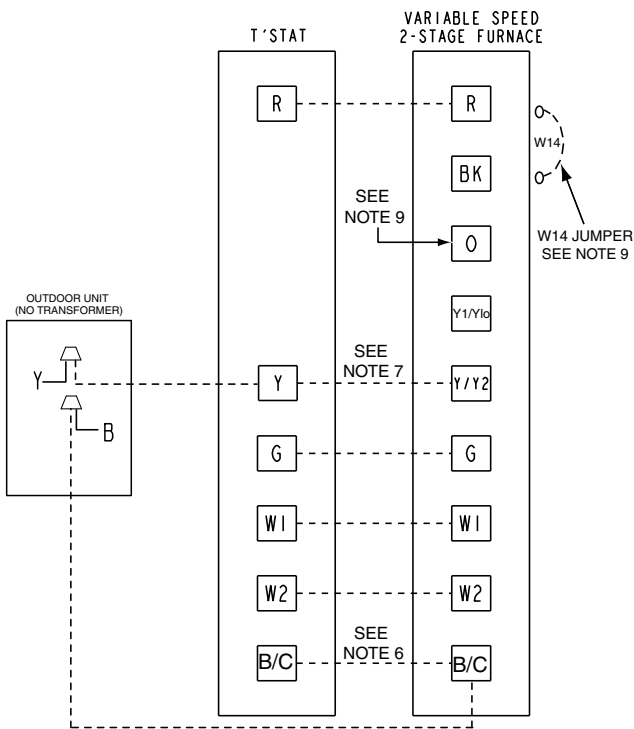

NOTE:

- 1.) BE SURE POWER AGREES WITH EQUIPMENT NAMEPLATE(S).
- 2.) LOW VOLTAGE (24V. WIRING) TO BE NO. 18AWG MIN..
- 3.) GROUNDING OF EQUIPMENT MUST COMPLY WITH LOCAL BUILDING CODES.
- 4.) SET THERMOSTAT HEAT ANTICIPATOR PER UNIT WIRING DIAGRAM.
- 5.) THESE LEADS PROVIDE 115V. POWER FOR CONNECTION OF THE HUMIDIFIER. MAX. LOAD 1.0 AMPS EACH.
- 6.) THIS WIRE IS ONLY FOR THERMOSTATS REQUIRING CONNECTION TO TRANSFORMER COMMON TERMINAL.
- 7.) THE "Y" TERMINAL FROM THE THERMOSTAT MUST BE WIRED TO THE "Y" TERMINAL OF THE FURNACE CONTROL FOR PROPER BLOWER OPERATION DURING COOLING.
- 8.) SET DIP SWITCHES WITH POWER OFF PER INSTALLATION INSTRUCTIONS TO SET AIRFLOW AND INDOOR FAN OFF DELAYS.
- 9.) OPTIONAL HUMIDISTAT IS TO BE CONNECTED BETWEEN "R" AND "BK". FACTORY INSTALLED JUMPER "R" TO "BK" ON THE CIRCUIT BOARD MUST BE CUT IF OPTIONAL HUMIDISTAT IS USED. THE JUMPER MUST ALSO BE CUT WHEN APPLYING AN AIRFLOW COMMAND SIGNAL TO THE "BK" INPUT SUCH AS WITH THE VARIABLE SPEED SINGLE-ZONE AND MULTI-ZONE SYSTEM CONTROLLERS. ON SINGLE SPEED COOLING ONLY / NON-HEAT PUMP SYSTEMS, JUMPER "Y" TO "O" FOR PROPER OPERATION OF THE DELAY PROFILES AND THE HUMIDISTAT. FOR TWO COMPRESSOR OR TWO SPEED SYSTEMS, JUMPER "YLO" TO "O".

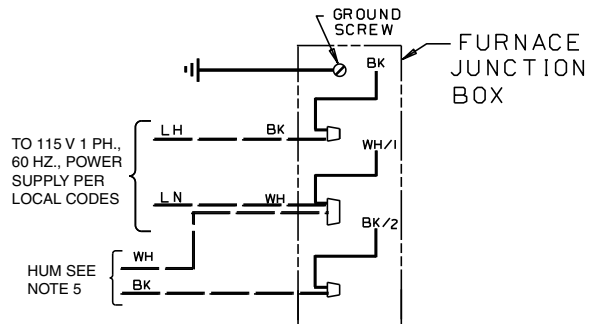

INTER-COMPONENT WIRING

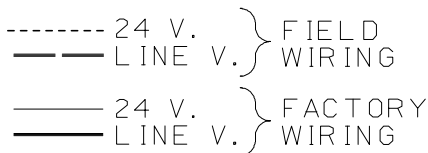

From Dwg. B342020 Rev. 0



Field Wiring

FIELD WIRING DIAGRAM FOR VARIABLE SPEED 2 STAGE FURNACE 2 STAGE HEATING, 2 STAGE COOLING (OUTDOOR SECTION WITHOUT TRANSFORMER)

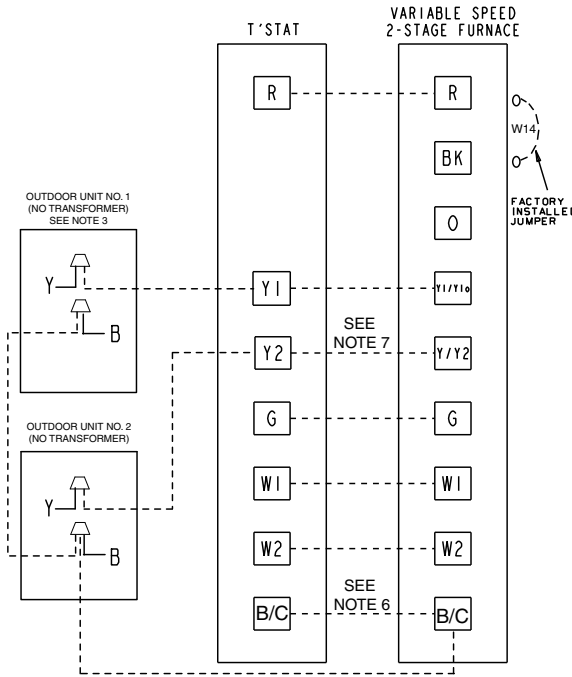

NOTES:

1. BE SURE POWER AGREES WITH EQUIPMENT NAMEPLATE(S)
2. LOW VOLTAGE(24 V. WIRING) TO BE NO. 18 A.W.G. MIN.
3. GROUNDING OF EQUIPMENT MUST COMPLY WITH LOCAL CODES.
4. SET THERMOSTAT HEAT ANTICIPATOR PER UNIT WIRING DIAGRAM.
5. THESE LEADS PROVIDE 115 V. POWER FOR CONNECTION OF THE HUMIDIFIER MAX. LOAD 1.0 AMPS EACH.
6. THIS WIRE IS ONLY FOR THERMOSTATS REQUIRING CONNECTION TO TRANSFORMER COMMON TERMINAL.
7. THE "Y2" TERMINAL FROM THE THERMOSTAT MUST BE WIRED TO THE "Y" TERMINAL OF THE FURNACE CONTROL FOR PROPER BLOWER OPERATION DURING COOLING.
8. SET DIP SWITCHES WITH POWER OFF PER INSTALLATION INSTRUCTIONS TO SET AIRFLOW AND INDOOR FAN OFF DELAYS.
9. OPTIONAL HUMIDISTAT IS TO BE CONNECTED BETWEEN R AND BK. FACTORY INSTALLED JUMPER R TO BK ON THE CIRCUIT BOARD MUST BE CUT IF OPTIONAL HUMIDISTAT IS USED. THE JUMPER MUST ALSO BE CUT WHEN APPLYING AN AIRFLOW COMMAND SIGNAL TO THE BK INPUT SUCH AS WITH THE VARIABLE SPEED SINGLE-ZONE AND MULTI-ZONE SYSTEM CONTROLLERS, ON SINGLE SPEED COOLING ONLY/NON-HEAT PUMP SYSTEMS, JUMPER Y TO O FOR PROPER OPERATION OF THE DELAY PROFILES AND THE HUMIDISTAT. FOR TWO COMPRESSOR OR TWO SPEED SYSTEMS, JUMPER YLO TO O.

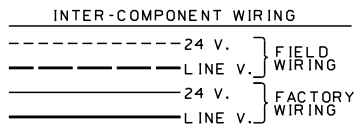
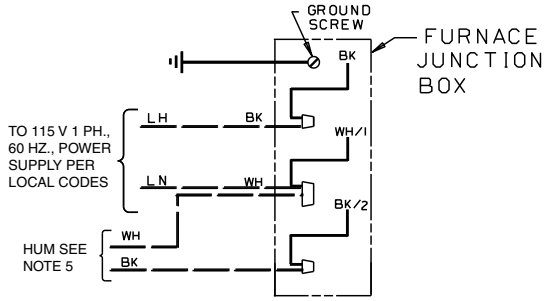

From Dwg. B342018 Rev. 0



Trane
6200 Troup Highway
Tyler, TX 75707
www.trane.com



Since **Trane** has a policy of continuous product improvement, **it** reserves the right to change design and specifications without notice.